

**BRILLIANT WATER & SEWER DISTRICT  
JEFFERSON COUNTY, OHIO**

**2023 WATER LINE REPLACEMENT**

**ADDENDUM #3**

**OCTOBER 25, 2024**

**THRASHER PROJECT #T10-11022**

TO WHOM IT MAY CONCERN:

The following are clarifications and responses to questions posed by contractors for the above-referenced project.

**A. GENERAL**

1. **THE BID FORM HAS BEEN REVISED. YOU MUST USE THE REVISED BID FORM WHEN PREPARING YOUR BID PACKAGE FOR THIS PROJECT.**

**B. SPECIFICATIONS**

1. **The following revised Specification is included in this addendum:  
012000 Price and Payment.**

**C. DRAWINGS**

1. **The following revise Plan Sheets are included in this addendum:  
Plan Sheets 9, 10, 11, 15, 19, and D2.**

**D. QUESTIONS AND RESPONSES**

**1. QUESTION**

What are the Driveway Pavement Replacement Specifications?

**RESPONSE**

All driveways being replaced are to match existing. See revised Sheet D2 for asphalt, concrete and gravel driveway repair details.

**2. QUESTION**

Will the District have a Wage and Hour coordinator to verify wages, benefits, and hours (regular and overtime) are being paid?

**RESPONSE**

Thrasher's RPR will be verifying the wage rates for the District.

**3. QUESTION**

Is the Ohio Rollover bond good for this project?

**RESPONSE**

No.

**4. QUESTION**

In General, when an MJ Tee is called out as a 6" MJ Tee or an 8" MJ Tee, we assume that all branches are the same?

**RESPONSE**

Correct.

**5. QUESTION**

Pursuant to the various tie-ins, could you advise as to the type of material of the existing water lines?

**RESPONSE**

The existing water lines are cast iron.

**6. QUESTION**

Plan Page No.11, Note Number 2, Station 113+00: Could you provide more clarity regarding the tie-in connection?

**RESPONSE**

The water line through the alley is to be removed and replaced. Note number 2 is to tie in after the proposed 6-inch line is installed.

**7. QUESTION**

Plan Page No. 13, Note Number 2, Station 205+68: Could you provide more clarity regarding the tie-in connection?

**RESPONSE**

The water line along 5<sup>th</sup> Street can be shut down and the water line connected with the necessary fittings.

**8. QUESTION**

Plan Page No. 14, Note Number 5, Station 208+61: Could you provide more clarity regarding the tie-in connection?

**RESPONSE**

**Bid items 16 and 17** for 6” and 8” hot taps have been added.

**9. QUESTION**

Plan Page No. 15, Note Number 2, Station 303+97: Could you provide more clarity regarding the tie-in connection?

**RESPONSE**

The water line through the alley shall be removed and replaced. Note number 2 is to tie into the existing 6-inch gate valve on Isabelle Street.

**10. QUESTION**

Plan Page No. 19, Note Number 3, Station 600+17: Could you provide more clarity regarding the tie-in connection?

**RESPONSE**

See revised Plan Sheet 19 attached to this addendum.

**11. QUESTION**

Plan Page No. 19, Note Number 2, Station 603+15: Could you provide more clarity regarding the tie-in connection?

**RESPONSE**

Install 8-inch tee and 8-inch gate valve.

**12. QUESTION**

Plan Page No. 22, Note Number 2, Station 700+00: The note calls out a 6” Tee to be installed. The plans show an 8” 90-degree bend to be installed. Would you clarify this discrepancy?

**RESPONSE**

Note number 2 should read 8” Tee.

**13. QUESTION**

Regarding Driveways: Do you have a table prepared for the type and size (length) of the existing driveways?

**RESPONSE**

No.

**14. QUESTION**

Would you provide Plan and Profile Drawings for Add Alternate No. 1, Gilchrist Street?

**RESPONSE**

There are no drawings available for this part of the project.

**15. QUESTION**

Plan Pages 3 and 4, Hill Street, from Station 10+00 to Station 17+00, the existing Sanitary Sewer, based on field measurements, is about 5' deep or about the same elevation as the proposed water line.

Will it be the contractor's responsibility to camera this line in order to locate laterals and avoid utility conflicts?

**RESPONSE**

Yes.

**16. QUESTION**

Plan Pages 9, 10 and 11, Alley Way between Labelle Street and Second Street. Several of the existing structures have gas meters, however, the plans do not show any gas lines in the street.

Would you provide a revised drawing indicating the location of the Gas Main?

**RESPONSE**

See the revised Sheets 9, 10, and 11 attached to this Addendum.

If you have any questions or comments, please feel free to contact me at your earliest convenience at [afechko@thethrashergroup.com](mailto:afechko@thethrashergroup.com). As a reminder, bids will be received until 1:00 p.m. on Thursday, November 7, 2024, at the Brilliant Fire Department located at 1001 3<sup>rd</sup> St, Brilliant, OH 43913. Good luck to everyone and thank you for your interest in the project.

Sincerely,  
THE THRASHER GROUP, INC.

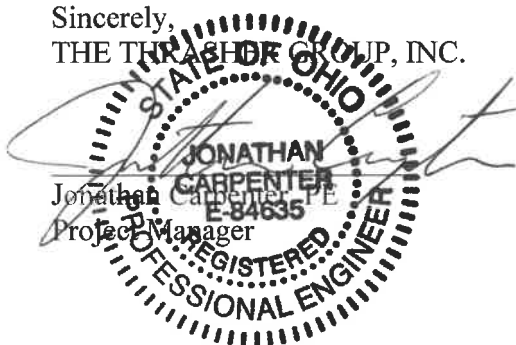

# BID FORM FOR CONSTRUCTION CONTRACT

The terms used in this Bid with initial capital letters have the meanings stated in the Instructions to Bidders, the General Conditions, and the Supplementary Conditions.

## ARTICLE 1—OWNER AND BIDDER

1.01 This Bid is submitted to:

*Brilliant Water & Sewer District  
706 2<sup>nd</sup> Street  
Brilliant, OH 43913*

1.02 The undersigned Bidder proposes and agrees, if this Bid is accepted, to enter into an Agreement with Owner in the form included in the Bidding Documents to perform all Work as specified or indicated in the Bidding Documents for the prices and within the times indicated in this Bid and in accordance with the other terms and conditions of the Bidding Documents.

## ARTICLE 2—ATTACHMENTS TO THIS BID

2.01 The following documents are submitted with and made a condition of this Bid:

A. Bid Opening Requirements

## ARTICLE 3—BASIS OF BID—LUMP SUM BID AND UNIT PRICES

### GENERAL

The Bidder shall take notice of and shall be responsible for any local or state taxes levied and applicable, and the cost for the same shall be included as part of the submitted Bid.

The total Bid cost stated includes a complete operating installation including furnishing and installation of any and all changes or additions in plans, piping, mechanical work, additional electrical work, accessories, controls, etc. necessary to accommodate alternative equipment systems or materials used in construction.

### BID PROPOSAL

The Bidder agrees to perform all required Work described in the detailed Specifications and as shown on the Plans for the complete construction and placing in satisfactory operation the **2023 Water Line Replacement project**. The Project "Sequence of Construction" has been detailed in the Drawings and Specification Division 1, Project Summary, Section 011000. The Bidder agrees to perform all the Work proposed for the total of the following Bid prices.

3.01 *Lump Sum Bids*

A. Bidder will complete the Work in accordance with the Contract Documents for the lump sum (stipulated) price(s), together with any Unit Prices indicated in Paragraph 3.02 and shown in the bid schedule.

B. Lump Sum Bids may be one of the following:

1. Lump Sum Price (Single Lump Sum)

- 2. Lump Sum Price (Base Bid and Alternates)
- 3. Lump Sum Price (Sectional Lump Sum Bids)
- C. All specified cash allowance(s) are included in the price(s) set forth in the bid schedule and have been computed in accordance with Paragraph 13.02 of the General Conditions.
- D. All specified contingency allowances are included in the price(s) set forth in the bid schedule and have been computed in accordance with Paragraph 13.02 of the General Conditions.

3.02 *Unit Price Bids*

- A. Bidder will perform the following Work at the indicated unit prices as shown in the Bid Schedule.
- B. Bidder acknowledges that:
  - 1. each Bid Unit Price includes an amount considered by Bidder to be adequate to cover Contractor’s overhead and profit for each separately identified item, and
  - 2. estimated quantities are not guaranteed, and are solely for the purpose of comparison of Bids, and final payment for all Unit Price Work will be based on actual quantities, determined as provided in the Contract Documents.

3.03 *Total Bid Price (Lump Sum and Unit Prices)*

**PROPOSED  
 2023 WATER LINE REPLACEMENT  
 FOR THE  
 BRILLIANT WATER & SEWER DISTRICT  
 JEFFERSON COUNTY, OHIO  
 THRASHER PROJECT #T10-11022**

**BID SCHEDULE**

BASE BID					
Item #	DESCRIPTION	QTY.	UNIT	UNIT COST	TOTAL COST
1	MOBILIZATION/ DEMOBILIZATION	1	LS		
2	CONSTRUCTION LAYOUT STAKES AND SURVEYING	1	LS		
3	PRE-CONSTRUCTION VIDEO	1	LS		
4	TRAFFIC CONTROL	1	LS		
5	EROSION AND SEDIMENT CONTROLS	1	LS		

BASE BID					
Item #	DESCRIPTION	QTY.	UNIT	UNIT COST	TOTAL COST
6	6 INCH PVC C900 DR-14 WATERLINE	6,600	LF		
7	8 INCH PVC C900 DR-14 WATERLINE	2,950	LF		
8	6 INCH M.J.T GATE VALVE WITH BOX AND LID, <b>COMPLETE</b>	30	EA		
9	8 INCH M.J.T GATE VALVE WITH BOX AND LID, <b>COMPLETE</b>	10	EA		
10	TIE INTO EXISTING 6 INCH WATER LINE	<b>6</b>	EA		
11	TIE INTO EXISTING 8 INCH WATER LINE	<b>7</b>	EA		
12	REMOVE EXISTING FIRE HYDRANT ASSEMBLY	10	EA		
13	FIRE HYDRANT ASSEMBLY, <b>COMPLETE</b>	19	EA		
14	¾ INCH SERVICE CONNECTION	180	EA		
<b>15</b>	<b>LANDSCAPING</b>	<b>4</b>	<b>LS</b>		
<b>15</b>	<b>REMOVE AND REPLACE W/ 6 INCH PVC C900 DR-14 WATER LINE (REMOVE AND REPLACE)</b>	<b>1,700</b>	<b>LF</b>		
<b>16</b>	<b>6 INCH HOT TAP TIE INTO EXISTING WATER LINE</b>	<b>4</b>	<b>EA</b>		
<b>17</b>	<b>8 INCH HOT TAP TIE INTO EXISTING WATER LINE</b>	<b>3</b>	<b>EA</b>		

**TOTAL BASE BID ACTIVITY (GENERAL)** \_\_\_\_\_

**GILCHRIST ST. BLOCK 1200 (ADDITIVE ALTERNATE 1)**

Item #	DESCRIPTION	QTY.	UNIT	UNIT COST	TOTAL COST
<b>18</b>	6 INCH PVC C900 DR-14 WATER LINE	1000	LF		
<b>19</b>	6 INCH M.J.T GATE VALVE WITH BOX AND LID, <b>COMPLETE</b>	3	EA		
<b>20</b>	FIRE HYDRANT ASSEMBLY, <b>COMPLETE</b>	1	EA		
<b>21</b>	REMOVE EXISTING FIRE HYDRANT ASSEMBLY	1	EA		

Item #	DESCRIPTION	QTY.	UNIT	UNIT COST	TOTAL COST
22	<del>3/4" SERVICE CONNECTION (INCLUDING CORP STOPS, CURB STOPS, AND CURB BOXES)</del>	14	EA		

**TOTAL BID ACTIVITY (ADDITIVE ALTERNATE 1) \_\_\_\_\_**

**MILLING WITH 1.5" OVERLAY ON EACH STREET (ADDITIVE ALTERNATE 2)**

Item #	DESCRIPTION	QTY.	UNIT	UNIT COST	TOTAL COST
23	KELLY WAY 0+00-3+00	300	LF		
24	HILL STREET 3+00 – 18+50	1,550	LF		
25	HYLAND STREET 18+50 – 33+50	1,500	LF		
26	ALLEY WAY 100+00 – 113+10	310	LF		
27	5 <sup>TH</sup> STREET 200+00 – 205+50	550	LF		
28	OHIO STREET 205+00 – 210+00	500	LF		
29	ALLEY WAY 300+00 – 304+00	400	LF		
30	ALLEY WAY 400+00 – 405+50	550	LF		
31	WALLACE STREET 500+00 – 502+00	200	LF		
32	GREEN ROAD 502+00 – 505+00	300	LF		
33	LABELLE STREET 600+00 – 604+00	400	LF		
34	PROSPECT STREET 800+00 – 805+75	575	LF		
35	RAILROAD ROAD 700+00 – 710+00	1,000	LF		
36	ROSS STREET 710+00 – 712+50	250	LF		
37	STROWBRIDGE STREET 900+00 – 904+50	450	LF		
38	GILCHRIST STREET	1,000	LF		

**TOTAL BID ACTIVITY (ADDITIVE ALTERNATE 2) \_\_\_\_\_**



NOTE: The Contractor's Unit Prices shall include purchase and installation, complete in place, per Bid item in accordance with the detailed Specifications.

Bidder acknowledges that (1) each Bid Unit Price includes an amount considered by Bidder to be adequate to cover Contractor's overhead and profit for each separately identified item, and (2) estimated quantities are not guaranteed, and are solely for the purpose of comparison of Bids, and final payment for all unit price Bid items will be based on actual quantities, determined as provided in the Contract Documents.

3.04 *Method of Award [NOTE: Select the proper Method shown below including Alternates if utilized]*

~~**{Method of Award – Lowest Qualified Bidder (Regular)}**~~

~~——— If at the time this contract is to be awarded, the lowest total bid submitted by a qualified, responsive, responsible Bidder does not exceed the amount of funds then estimated by the Owner, as available to finance the contract, the construction contract will be awarded. If such bids exceeds such amount, the owner may reject all bids.~~

~~A. Unit prices have been computed in accordance with paragraph 13.03.A of the General Conditions.~~

~~B. Bidder acknowledges that estimated quantities are not guaranteed, and are solely for the purpose of comparison of Bids, and final payment for all Unit Price Bid items will be based on actual quantities, determined as provided in the Contract Documents.~~

~~**{OR}**~~

~~**{Method of Award – Lowest Qualified Bidder (Deductive Alternate)}**~~

~~——— If at the time this Contract is to be awarded, the lowest total bid submitted by a qualified, responsive, responsible bidder, as listed in contract does not exceed the amount of funds estimated by the Owner, as available to finance the contract, the construction contract will be awarded. If such bids exceeds such amount, the Owner may reject all bids. The Owner may award the contract on the total bid submitted by a qualified, responsive, responsible bidder, less the amount(s) of the deductive alternate(s) subtracted in numerical order to produce the lowest bid within the funds available for financing.~~

~~A. Unit prices have been computed in accordance with paragraph 13.03.A of the General Conditions.~~

~~B. Bidder acknowledges that estimated quantities are not guaranteed, and are solely for the purpose of comparison of Bids, and final payment for all Unit Price Bid items will be based on actual quantities, determined as provided in the Contract Documents.~~

~~**{OR}**~~

**Method of Award - Lowest Qualified Bidder (Additive Alternates)**

*{Apply in numerical order as in deductive}*

If at the time this contract is to be awarded, the lowest total bid submitted by a qualified, responsive, responsible Bidder does not exceed the amount of funds then estimated by the Owner, as available to finance the contract, the construction contract will be awarded. Awarding of Additive Alternate(s) will not affect the lowest Bidder. If such bids exceed such amount, the Owner may reject all bids.

The Owner will award the contract on the total base bid amount inclusive or exclusive of alternates as determined by the Owner and submitted by a qualified, responsive, responsible Bidder. The Owner may elect to award any or all of the additive alternates in no particular order.

- A. Unit prices have been computed in accordance with paragraph 13.03.A of the General Conditions.
- B. Bidder acknowledges that estimated quantities are not guaranteed, and are solely for the purpose of comparison of Bids, and final payment for all Unit Price Bid items will be based on actual quantities, determined as provided in the Contract Documents.

**{OR}**

~~**{Method of Award = Lowest Qualified Bidder (Multiple Contracts)}**~~

~~*{Only if Necessary, If one company bids all contracts, they can add a % deduction to their total bid}*~~

~~—— If at the time this contract is to be awarded, the lowest total bid submitted by a qualified, responsive, responsible Bidder does not exceed the amount of funds then estimated by the Owner, as available to finance the contract, the construction contract will be awarded. If such bids exceeds such amount, the owner may reject all bids. The Owner may award the contract on the total bid submitted by a qualified, responsive, responsible bidder after apply the % deduct, if offered, as listed in contract to produce the lowest bid within the funds available for financing.~~

- ~~A. Unit prices have been computed in accordance with paragraph 13.03.A of the General Conditions.~~
- ~~B. Bidder acknowledges that estimated quantities are not guaranteed, and are solely for the purpose of comparison of Bids, and final payment for all Unit Price Bid items will be based on actual quantities, determined as provided in the Contract Documents.~~

**{OR}**

~~**{Method of Award = Lowest Qualified Bidder (Alternate Bids)}**~~

~~—— If at the time this contract is to be awarded, the lowest total bid or either alternate total bid submitted by a qualified, responsive, responsible Bidder does not exceed the amount of funds then estimated by the Owner, as available to finance the contract, the construction contract will be awarded.~~

If such bids exceeds such amount, the owner may reject all bids. The Owner may award the contract on the total bid or either alternate total bid submitted by a qualified, responsive, responsible bidder less the amount of the deductive alternate as listed in contract to produce the lowest bid within the funds available for financing.

- A. ~~Unit prices have been computed in accordance with paragraph 13.03.A of the General Conditions.~~
- B. ~~Bidder acknowledges that estimated quantities are not guaranteed, and are solely for the purpose of comparison of Bids, and final payment for all Unit Price Bid items will be based on actual quantities, determined as provided in the Contract Documents.~~

**ARTICLE 4 ~~BASIS OF BID COST PLUS FEE~~**

4.01 ~~The Contract Price will be the Cost of the Work, determined as provided in Paragraph 13.01 of the General Conditions, together with the following fee, and subject to the Guaranteed Maximum Price.~~

4.02 *Contractor's Fee*

- A. ~~Contractor's fee will be [number] percent of the Cost of the Work. No fee will be payable on the basis of costs itemized as excluded in Paragraph 13.01.C of the General Conditions.~~
  - 1. ~~The maximum amount payable by Owner as a percentage fee (Guaranteed Maximum Fee) will not exceed \$[insert cap amount], subject to increases or decreases for changes in the Work.~~
- B. ~~Contractor's fee will be determined by applying the following percentages to the various portions of the Cost of the Work as defined in Article 13 of the General Conditions. No fee will be payable on the basis of costs itemized as excluded in Paragraph 13.01.C of the General Conditions:~~

<b>Costs</b>	<b>Percent</b>
Payroll costs (See Paragraph 13.01.B.1, General Conditions)	
Materials and Installed Equipment cost (GC 13.01.B.2)	
Amounts to be paid to Subcontractors (GC 13.01.B.3)	
Amount to be paid to special consultants (GC 13.01.B.4)	
Other costs (GC 13.01.B.5)	

- 1. ~~The maximum amount payable by Owner as a percentage fee (Guaranteed Maximum Fee) will not exceed \$[insert cap amount], subject to increases or decreases for changes in the Work.~~
- C. ~~Contractor's fee will be the fixed sum of \$[number].~~

4.03 *Guaranteed Maximum Price*

- A. ~~The Guaranteed Maximum Price to Owner of the Cost of the Work including Contractor's Fee will not exceed \$[Bidder fill in GMP].~~

Deleted

**ARTICLE 5 ~~PRICE PLUS TIME BID~~**

5.01 *Price Plus Time Contract Award (Stipulated Price Contract)*

- A. ~~The Bidder to which an award of the Contract will be made will be determined in part on the basis of the Total Bid Price and the total number of calendar days to substantially complete the Work, in accordance with the following:~~

	Description		Amount
A	1. Total Bid Price		\$_{number}
	2. Total number of calendar days to substantially complete the Work	{number} days	
	3. Liquidated Damages Rate (from Agreement)	\$_{number}/day	
B	4. Adjustment Amount (2 x 3)		\$_{number}
A+B	5. Amount for Comparison of Bids		\$_{number}

~~B. The purpose of the process in the table above is only to calculate the lowest price plus time (A+B) bid amount for bid comparison purposes. The price for completion of the Work (the Contract Price) is the Total Bid Price.~~

~~C. Bonds required under Paragraph 6.01 of the General Conditions will be based on the Contract Price.~~

5.02 *Price Plus Time Contract Award (Cost Plus Fee with Guaranteed Maximum Price Contract)*

A. The Bidder to which an award of Contract will be made will be determined in part on the basis of the Guaranteed Maximum Price and the total number of calendar days to substantially complete the Work, in accordance with the following:

	Description		Amount
A	1. Guaranteed Maximum Price		\$_{number}
	2. Total number of calendar days to substantially complete the Work	{number} days	
	3. Liquidated Damages Rate (from Agreement)	\$_{number}/day	
B	4. Adjustment Amount (2 x 3)		\$_{number}
A+B	5. Amount for Comparison of Bids		\$_{number}

~~B. The purpose of the process in the table above is only to calculate the lowest price plus time (A+B) bid amount for bid comparison purposes. The price for completion of the Work (the Contract Price) is based on the cost of the Work, plus a fee, subject to a guaranteed maximum price, as set forth in the Agreement.~~

~~C. Bonds required under Paragraph 6.01 of the General Conditions will be based on the Contract Price.~~

~~Deleted~~

**ARTICLE 6—TIME OF COMPLETION**

6.01 Bidder agrees that the Work will be substantially complete and will be completed and ready for final payment in accordance with Paragraph 15.06 of the General Conditions on or before the dates or within the number of calendar days indicated in the Agreement.

~~6.02 Bidder agrees that the Work will be substantially complete on or before [Bidder inserts date], and will be completed and ready for final payment in accordance with Paragraph 15.06 of the General Conditions on or before [Bidder inserts date].~~

~~Deleted~~

~~6.03 Bidder agrees that the Work will be substantially complete within [Bidder inserts number] calendar days after the date when the Contract Times commence to run as provided in Paragraph 4.01 of the General Conditions, and will be completed and ready for final payment in accordance with Paragraph 15.06 of the General Conditions within [Bidder inserts number] calendar days after the date when the Contract Times commence to run.~~

~~Deleted~~

6.04 Bidder accepts the provisions of the Agreement as to liquidated damages.

## ARTICLE 7—BIDDER’S ACKNOWLEDGEMENTS: ACCEPTANCE PERIOD, INSTRUCTIONS, AND RECEIPT OF ADDENDA

### 7.01 *Bid Acceptance Period*

- A. This Bid will remain subject to acceptance for 90 days after the Bid opening, or for such longer period of time that Bidder may agree to in writing upon request of Owner.

### 7.02 *Instructions to Bidders*

- A. Bidder accepts all of the terms and conditions of the Instructions to Bidders, including without limitation those dealing with the disposition of Bid security.

### 7.03 *Receipt of Addenda*

- A. Bidder hereby acknowledges receipt of the Addenda: **ACKNOWLEDGE IN BOR-4.**

## ARTICLE 8—BIDDER’S REPRESENTATIONS AND CERTIFICATIONS

### 8.01 *Bidder’s Representations*

- A. In submitting this Bid, Bidder represents the following:
1. Bidder has examined and carefully studied the Bidding Documents, including Addenda.
  2. Bidder has visited the Site, conducted a thorough visual examination of the Site and adjacent areas, and become familiar with the general, local, and Site conditions that may affect cost, progress, and performance of the Work.
  3. Bidder is familiar with all Laws and Regulations that may affect cost, progress, and performance of the Work.
  4. Bidder has carefully studied the reports of explorations and tests of subsurface conditions at or adjacent to the Site and the drawings of physical conditions relating to existing surface or subsurface structures at the Site that have been identified in the Supplementary Conditions, with respect to the Technical Data in such reports and drawings.
  5. Bidder has carefully studied the reports and drawings relating to Hazardous Environmental Conditions, if any, at or adjacent to the Site that have been identified in the Supplementary Conditions, with respect to Technical Data in such reports and drawings.
  6. Bidder has considered the information known to Bidder itself; information commonly known to contractors doing business in the locality of the Site; information and observations obtained from visits to the Site; the Bidding Documents; and the Technical Data identified in the Supplementary Conditions or by definition, with respect to the effect of such information, observations, and Technical Data on (a) the cost, progress, and performance of the Work; (b) the means, methods, techniques, sequences, and procedures of construction to be employed by Bidder, if selected as Contractor; and (c) Bidder’s (Contractor’s) safety precautions and programs.
  7. Based on the information and observations referred to in the preceding paragraph, Bidder agrees that no further examinations, investigations, explorations, tests, studies, or data are necessary for the performance of the Work at the Contract Price, within the Contract Times, and in accordance with the other terms and conditions of the Contract.
  8. Bidder is aware of the general nature of work to be performed by Owner and others at the Site that relates to the Work as indicated in the Bidding Documents.
  9. Bidder has given Engineer written notice of all conflicts, errors, ambiguities, or discrepancies that Bidder has discovered in the Bidding Documents, and of discrepancies between Site conditions and the Contract Documents, and the written resolution thereof by Engineer is acceptable to Contractor.

10. The Bidding Documents are generally sufficient to indicate and convey understanding of all terms and conditions for performance and furnishing of the Work.
11. The submission of this Bid constitutes an incontrovertible representation by Bidder that without exception the Bid and all prices in the Bid are premised upon performing and furnishing the Work required by the Bidding Documents.

8.02 *Bidder's Certifications*

A. The Bidder certifies the following:

1. This Bid is genuine and not made in the interest of or on behalf of any undisclosed individual or entity and is not submitted in conformity with any collusive agreement or rules of any group, association, organization, or corporation.
2. Bidder has not directly or indirectly induced or solicited any other Bidder to submit a false or sham Bid.
3. Bidder has not solicited or induced any individual or entity to refrain from bidding.
4. Bidder has not engaged in corrupt, fraudulent, collusive, or coercive practices in competing for the Contract. For the purposes of this Paragraph 8.02.A:
  - a. Corrupt practice means the offering, giving, receiving, or soliciting of anything of value likely to influence the action of a public official in the bidding process.
  - b. Fraudulent practice means an intentional misrepresentation of facts made (a) to influence the bidding process to the detriment of Owner, (b) to establish bid prices at artificial non-competitive levels, or (c) to deprive Owner of the benefits of free and open competition.
  - c. Collusive practice means a scheme or arrangement between two or more Bidders, with or without the knowledge of Owner, a purpose of which is to establish bid prices at artificial, non-competitive levels.
  - d. Coercive practice means harming or threatening to harm, directly or indirectly, persons or their property to influence their participation in the bidding process or affect the execution of the Contract.

BIDDER hereby submits this Bid as set forth above:

Bidder:

\_\_\_\_\_

*(typed or printed name of organization)*

By:

\_\_\_\_\_

*(individual's signature)*

Name:

\_\_\_\_\_

*(typed or printed)*

Title:

\_\_\_\_\_

*(typed or printed)*

Date:

\_\_\_\_\_

*(typed or printed)*

*If Bidder is a corporation, a partnership, or a joint venture, attach evidence of authority to sign.*

Attest:

\_\_\_\_\_

*(individual's signature)*

Name:

\_\_\_\_\_

*(typed or printed)*

Title:

\_\_\_\_\_

*(typed or printed)*

Date:

\_\_\_\_\_

*(typed or printed)*

Address for giving notices:

\_\_\_\_\_  
\_\_\_\_\_

Bidder's Contact:

Name:

\_\_\_\_\_

*(typed or printed)*

Title:

\_\_\_\_\_

*(typed or printed)*

Phone:

\_\_\_\_\_

Email:

\_\_\_\_\_

Address:

\_\_\_\_\_  
\_\_\_\_\_  
\_\_\_\_\_

Bidder's Contractor License No.: (if applicable)

\_\_\_\_\_

## SECTION 012000 - PRICE AND PAYMENT PROCEDURES

### PART 1 - GENERAL

#### 1.1 RELATED DOCUMENTS

- A. Drawings and general provisions of the Contract Documents, including General and Supplementary Conditions, and all related Specification Sections, apply to this Section.

#### 1.2 SECTION INCLUDES

- A. Cash allowances.
- B. Schedule of Values.
- C. Application for Payment.
- D. Measurement and Payment

#### 1.3 CASH ALLOWANCES (If provided in the Bid Form)

- A. Costs Included in Cash Allowances: Cost of product to Contractor or Subcontractor, less applicable trade discounts; delivery to Site and applicable taxes unless stated otherwise in Allowance Schedule.
- B. Costs Not Included in Cash Allowances but Included in Contract Sum/Price: Product handling at Site including unloading, uncrating, and storage; protection of products from elements and from damage; and labor for installation and finishing unless stated otherwise in Allowance Schedule.
- C. Engineer Responsibilities:
  - 1. Consult with Contractor for consideration and selection of products suppliers and installers.
  - 2. Select products in consultation with Owner and transmit decision to Contractor.
  - 3. Prepare Change Order.
- D. Contractor Responsibilities:
  - 1. Assist Engineer in selection of products, suppliers, and installers.
  - 2. Obtain proposals from suppliers and installers and offer recommendations.
  - 3. Upon notification of selection by Engineer, execute purchase agreement with designated supplier and installer.
  - 4. Arrange for and process Shop Drawings, Product Data, and Samples. Arrange for delivery.
  - 5. Promptly inspect products upon delivery for completeness, damage, and defects. Submit claims for transportation damage.



Brilliant Water & Sewer District  
2023 Water Line Replacement

- E. Differences in costs will be adjusted by Change Order.
  - F. Allowance Schedule: If provided in and as per the Bid Form
  - G. Differences in cost between allowance(s) and actual cost(s) will be adjusted by Change Order.
- 1.4 SCHEDULE OF VALUES (As required for Lump Sum Project or Bid Item Breakdown on Unit Price Project)
- A. Submit printed schedule on Progress Estimate schedule on EJCDC C-620.
  - B. Submit Schedule of Values within 20 days after date established in Notice to Proceed.
  - C. Format for Lump Sum Project: Use Table of Contents of this Project Manual. Identify each line item with number and title of major Specification Section.
  - D. Revise schedule to list approved Change Orders with each Application for Payment.
- 1.5 APPLICATION FOR PAYMENT
- A. Submit six (6) executed copies of each Application for Payment on EJCDC C-620 - Contractor's Application for Payment.
  - B. Submit six (6) copies of executed copies of Abnormal Weather Conditions forms regardless if any days are claimed or not and Affidavit of Payment.
  - C. Submit six (6) American Iron and Steel Qualifying and De Minimus Materials List (if required by the Contract Documents).
  - D. Payment Period: Submit at intervals stipulated in the Agreement.
- 1.6 MEASUREMENT AND PAYMENT
- A. Take measurements and compute quantities. Engineer will verify measurements and quantities.
  - B. Unit Quantities: Quantities and measurements indicated on Bid Form are for Contract purposes only. Actual quantities provided shall determine payment.
  - C. Payment Includes: Full compensation for required labor, products, tools, equipment, plant and facilities, transportation, services and incidentals; erection, application, or installation of item of the Work; overhead and profit.
  - D. Final payment for Work governed by unit prices will be made on basis of actual measurements and quantities accepted by Engineer multiplied by unit sum/price for Work incorporated in or made necessary by the Work.
  - E. Measurement of Quantities:

Brilliant Water & Sewer District  
2023 Water Line Replacement

1. Weigh Scales: Inspected, tested, and certified by state in which work is being performed or state of origin of materials within past year.
2. Platform Scales: Of sufficient size and capacity to accommodate conveying vehicle.
3. Metering Devices: Inspected, tested, and certified by state in which work is being performed or state of origin of materials within past year.
4. Measurement by Weight: Concrete reinforcing steel, rolled or formed steel, or other metal shapes will be measured by handbook weights. Welded assemblies will be measured by handbook or scale weight.
5. Measurement by Volume: Measured by cubic dimension using mean length, width, and height or thickness.
6. Measurement by Area: Measured by square dimension using mean length and width or radius.
7. Linear Measurement: Measured by linear dimension, at item centerline or mean chord.
8. Stipulated Sum/Price Measurement: Items measured by weight, volume, area, or linear means or combination, as appropriate, as completed item or unit of the Work.

F. Payment

1. **General Conditions, Supplemental General Conditions, Specification Section 011000 through 017839 Except for General Conditions - Mobilization/Demobilization, Section 015000 - Temporary Facilities and Controls and Section 015700 – Traffic Control.**

**Incidental**

- A. The cost of this work shall be included in the lump sum bid price(s) and/or unit bid price(s) for the bid item(s) for which it is required.
- B. No additional compensation shall be made.

2. **General Conditions – Mobilization/Demobilization**

**Bid Item 1 – Mobilization/Demobilization – Lump Sum**

- A. When a lump sum bid item for Mobilization/Demobilization is provided in the Bid Form, this work shall be paid for at the lump sum bid price for construction preparatory operations including, but not limited to, the movement of personnel and equipment to the project site and the establishment of field office(s), building(s), and/or other facilities, payment of all bonding and insurance costs incurred by the Contractor, and the installation of the project sign if a sign is required in the Supplemental General Conditions.

In no case shall the lump sum bid price for Mobilization/Demobilization exceed five percent (5%) of the total bid.

Partial payment not exceeding three percent (3%) of the awarded total contract bid price shall be made as part of the first application for payment after mobilization is completed. The balance of this lump sum bid price shall be paid for as part of the first application for payment after final completion.

No deduction shall be made, nor shall any increase be made, in the lump sum bid price for Mobilization regardless of any decreases or increases in the final total contract price or for any other cause.

- B. When a bid item for Mobilization/Demobilization is not provided in the Bid Form, this work shall be included in the lump sum bid price(s) and/or unit bid price(s) for the bid item(s) for which mobilization/demobilization is required.

No additional compensation shall be made.

**3. Section 015000 – Temporary Facilities and Controls**

**Incidental**

- A. When a lump sum bid item for Field Office and Sheds is provided in the Bid Form, this work shall be paid for on a prorated basis over the contract length to final completion based on the lump sum bid price.
- B. When a per month bid item for Field Office and Sheds is provided in the Bid Form, this work shall be paid for at the per month bid price.
- C. When a lump sum bid item for Field Office and Sheds is not provided in the Bid Form and a lump sum bid item for Mobilization/Demobilization is provided in the Bid Form, this work shall be included in the lump sum bid price for Mobilization/Demobilization.
- D. When neither a lump sum bid item for Field Office and Sheds is provided in the Bid Form nor a lump sum bid item for Mobilization is provided in the Bid Form, the cost for Field Office and Sheds shall be included in the lump sum bid price(s) and/or unit bid price(s) for the bid item(s) for which the Field Office and Sheds are required. No additional compensation shall be made.

**4. Section 015700 – Traffic Control**

**Bid Item 4 – Traffic Control – Lump Sum**

- A. When a Lump Sum bid item for Traffic Control is provided in Bid Form, this work shall be paid for at the lump sum bid price or unit bid price.
- B. When a bid item for Traffic Control is not provided in the Bid Form, this work shall be included in the lump sum bid price(s) and/or unit bid price(s) for the bid item(s) for which Traffic Control is required.
- C. No additional compensation shall be made.

**5. Section 017419 – Construction Waste Management and Disposal**

**Bid Item 12 – Remove Existing Fire Hydrant Assembly– Each**

**Bid Item 21 – Remove Existing Fire Hydrant Assembly– Each**

- A. Waste management services associated with the removal and return of a fire hydrant owned by the Brilliant Water and Sewer District shall be paid for at the lump sum bid price for such removal. This lump sum shall include all excavation, labor, and surface restoration required to remove the hydrant from service as well as all storage and delivery costs to return the hydrant to Brilliant Water and Sewer District.
- B. All waste management and disposal conducted for reasons other than the recovery and return of the Brilliant Water and Sewer District fire hydrant shall be paid for as part of the bid price

of the bid items for which it is required. No additional compensation shall be made for waste management and disposal except as outlined under Bid Item 12.

**6. Section 024010 – Video Recording**

**Bid Item 3 – Pre-Construction Video Recording – Lump Sum**

- A. When a lump sum bid item for Pre-Construction Video Recording is provided in the Bid Form, this work shall be paid for at the lump sum bid price for all location(s) directly and/or indirectly affected by the project.
- B. When a bid item for Pre-Construction Video Recording is not provided in the Bid Form, this work will be completed by others and will not be part of the Contractor's work.

**7. Section 033000 – Cast-in-Place Concrete**

**Incidental**

- A. The cost of this work shall be included in the lump sum bid price(s) and/or unit bid price(s) for the bid item(s) for which cast-in-place concrete is required.
- B. No additional compensation shall be made.

**8. Section 310513 – Soils for Earthwork**

**Incidental**

- A. The cost of this work shall be included in the lump sum bid price(s) and/or unit bid price(s) for the bid item(s) for which soils for earthwork is required.
- B. No additional compensation shall be made.

**9. Section 310516 – Aggregates for Earthwork**

**Incidental**

- A. The cost of this work shall be included in the lump sum bid price(s) and/or unit bid price(s) for the bid item(s) for which aggregates for earthwork is required.
- B. No additional compensation shall be made.

**10. Section 311100 – Clearing, Grubbing, and Restoration**

**Clearing, Grubbing, and Restoration of Disturbed Areas - Incidental**

- A. The cost for this work shall be included in the lump sum bid price(s) and/or unit bid price(s) for the bid item(s) for which clearing and/or grubbing are required.
- B. No additional compensation shall be made.
- C. All trees and vegetation within temporary construction easement limits shall be cleared (and grubbed if so specified) unless the property owner indicates in writing that certain trees are

to remain, and that the property owner will assume all responsibilities for removal of the trees in the future. Any such letter from the property owner shall be submitted to the Engineer for the record.

**11. Section 312316 – Excavation**

**Incidental**

- A. The cost of this work shall be included in the lump sum bid price(s) and/or unit bid price(s) for the bid item(s) for which excavation is required. No additional compensation shall be made.
- B. Unless otherwise provided, all excavation shall be unclassified regardless of the material encountered. No additional compensation shall be made for rock or any soft or otherwise unsuitable material. No additional compensation shall be made for dewatering and/or sheet piling.

**12. Section 312316.13 – Trenching**

**Incidental**

- A. The cost of this work shall be included in the lump sum bid price(s) and/or unit bid price(s) for the bid item(s) for which trenching is required. No additional compensation shall be made.
- B. Unless otherwise provided, all excavation shall be unclassified regardless of the material encountered. No additional compensation shall be made for rock or any soft or otherwise unsuitable material. No additional compensation shall be made for dewatering and/or sheet piling.

**13. Section 312319 – Dewatering**

**Incidental**

- A. The cost of this work shall be included in the lump sum bid price(s) and/or unit bid price(s) for the bid item(s) for which dewatering is required.
- B. No additional compensation shall be made.

**14. Section 312323.33 – Flowable Fill**

**Incidental**

- A. The cost of this work shall be included in the lump sum bid price(s) and/or unit bid price(s) for the bid item(s) for which flowable fill is required.
- B. No additional compensation shall be made.

**15. Section 312500 – Erosion and Sedimentation Controls**

**Bid Item 5 – Erosion and Sedimentation Controls – Lump Sum**

- A. When a lump sum bid item of Erosion and Sedimentation Controls is provided in the Bid Form, this work shall be paid for at the lump sum bid price for all erosion and sedimentation controls at all locations directly and/or indirectly disturbed by the project.

All operation and maintenance costs as well as recordkeeping and reporting costs shall be included in the lump sum bid item.

- B. When a bid item for Erosion and Sediment Controls is not provided in the Bid Form, this work shall be included in the lump sum bid price(s) and/or unit bid price(s) for the bid item(s) for which Erosion and Sediment Controls are required.

All operation and maintenance costs as well as recordkeeping and reporting costs shall be included.

- C. No additional compensation shall be made.

**16. Section 321216 – Concrete Resurfacing, Crushed Stone Resurfacing, and Asphalt Paving**

**Bid Items 23-38 – Milling with 1.5” Asphalt Overlay** of Each Street (Additive Alternate 2) – Per Linear Foot

Or

**Incidental**

- A. Trench repairs, street, roadway, and driveway asphalt driveway repairs, bituminous concrete curb, and crushed stone repairs as required in the Drawings and/or Specifications shall be included in the lump **sum** bid price(s) and/or unit bid price(s) for the bid item(s) for which the work is required.
- B. Pavement, graveled areas, curb, and/or sidewalk and vegetated areas disturbed by the Contractor in areas where utility pipe is not installed shall be replaced by the Contractor at his expense at no additional cost to the Owner. No additional compensation will be made.
- C. Improved and unimproved areas disturbed by the Contractor in areas where utility pipe is not installed shall be repaired by the Contractor at his expense at no additional cost to the Owner.
- D. The cost for the additive alternate shall include milling the existing pavement to a depth of 1.5” and installation of 1.5” of surface course.**
- E. No additional compensation shall be made.

**17. Section 321217 – Stone Surfacing Material**

**Incidental**

- A. The cost for this work shall be paid for at the linear foot unit bid price(s) for the type of repair specified measured along the centerline of the street or driveways, width shall no be considered.
- B. The cost for this Work shall be paid for by the linear foot unit bid price(s) for the type of repair specified for shoulder stone along state roads or streets, width shall not be considered.

- C. The cost of this work shall be paid for by the ton unit bid price(s) for parking areas.
- D. The cost for temporary stone to maintain disturbed areas until repairs are made shall be included in the unit bid price(s) for the repair(s). No additional compensation shall be made.

**18. Section 321723 – Pavement Markings**

**Incidental**

- A. The cost of this work shall be in the lump sum bid price(s) or unit bid price(s) for the paving improvement.
- B. No additional compensation shall be made.

**19. Section 329119 - Landscaping**

**Incidental**

- A. The cost of this work shall be paid **included in the unit bid price(s) as provided in the Bid Form for water line, valves, and fire hydrant assemblies.**

**20. Section 330526 – Utility Identification**

**Incidental**

- A. The cost of this work shall be included in the lump sum bid price(s) and/or unit bid price(s) for which utility identification is required.
- B. No additional compensation shall be made.

**21. Section 331113 – Water Distribution Piping**

**Bid Item 6 – 6” PVC C900 DR-14 Water Line – Per Linear Foot**

**Bid Item 7 - 8” PVC C900 DR-14 Water Line – Per Linear Foot**

**Bid Item 18 - 6” PVC C900 DR-14 Water Line – Per Linear Foot**

**Bid Item 10 – Tie-in to Existing 6” Water Line – Per Each**

**Bid Item 11 – Tie-in to Existing 8” Water Line – Per Each**

**Bid Item 15 – 6” PVC C900 DR-14 Water Line (Remove and Replace) – Per Linear Foot**

**Bid Item 16 – 6” Hot Tap Tie into Existing Water Line – Per Each**

**Bid Item 17 – 8” Hot Tap Tie into Existing Water Line – Per Each**

Brilliant Water & Sewer District  
2023 Water Line Replacement

- A. The cost for water line work shall be paid for at the linear foot unit bid price(s) for the size, type, and classification of water line pipe as provided in the Bid Form.
- B. The cost for water line work shall include, but not be limited to, bedding (where required in the Drawings and/or Specifications), water line pipe, polyethylene encasement for ductile iron pipe (where required in the Drawings and/or Specifications), traceable wire and related appurtenances (where required in the Drawings and/or Specifications), detectable warning tape, all fittings and concrete thrust blocks, shown in the Drawings, mechanical joint retainer restraints at all fittings shown in the Drawings, and concrete thrust blocks for fittings.
- C. The cost for remove and replace the water line shall include, and not limited to, the removal and disposal of the existing pipe, fittings, and valves. The cost shall also include but not limited to, the bedding (where required in the Drawings and/or Specifications), water line pipe, polyethylene encasement for ductile iron pipe (where required in the Drawings and/or Specifications), traceable wire and related appurtenances (where required in the Drawings and/or Specifications), detectable warning tape, all fittings and concrete thrust blocks, shown in the Drawings, mechanical joint retainer restraints at all fittings shown in the Drawings, and concrete thrust blocks for fittings.**
- D. Restoration of Disturbed Area, Concrete Resurfacing, Crushed Stone Resurfacing, and Asphalt Paving shall be paid for under other Bid Items(s) specified elsewhere.
- E. The cost for all fitting(s) and concrete thrust block(s) shall be included in the linear foot unit bid price(s) of the water line pipe. All mechanical joint fittings shall include mechanical joint retainer restraints at all fittings. No additional compensation shall be made.
- F. Fitting adaptors for iron pipe size pipe to ductile iron pipe fittings shall be provided for all fittings. No additional compensation shall be made.
- G. Fitting adaptors for iron pipe size pipe to ductile iron pipe fittings shall be provided for all fittings. No additional compensation shall be made.
- H. The cost for a tie-in of a new water line to an existing water line shall include, but not be limited to, all fitting(s), solid sleeve and/or couplings, a gate valve (including a valve box with lid, a concrete foundation, a valve box adaptor, and a concrete stabilizing block), traceable wire and related appurtenances (where required in the Drawings and/or Specifications), detectable warning tape, concrete thrust blocking, and all other appurtenances required in the Drawings and/or the Specifications.
- I. The cost for a hot tap tie-in of a new water line to an existing water line shall include, but not be limited to, a tapping sleeve and gate valve (including a valve box with lid, a concrete foundation, a valve box adaptor, and a concrete stabilizing block), fitting(s), traceable wire and related appurtenances (where required in the Drawings and/or Specifications), detectable warning tape, concrete thrust blocking, and all other appurtenances required in the Drawings and/or the Specifications.**

**22. Section 331200 – Water Utility Distribution Equipment**

**Incidental**

- A. The cost for this work shall be paid for at the per each bid price for the size and type of valve specified.



- B. The cost of the valve shall include, but not be limited to, a valve, mechanical joint retainer restraints at mechanical joint connections, a valve box with lid, and all other appurtenances required in the Drawings and/or Specifications.
- C. Restoration of Disturbed Area, Concrete Resurfacing, Crushed Stone Resurfacing, and Asphalt Paving shall be paid for under other Bid Items(s) specified elsewhere.

**23. Section 331213 – Water Service Connections**

**Bid Item 14 – ¾” Service Connection – Each**

**Bid Item 22 - ¾” Service Connection – Each**

- A. The cost for a new service connection shall include, but not be limited to, a service saddle, a corporation stop, five feet (5’) of new service tubing on the customer side, the connection to the existing service line as required including pack joint coupling, and demolition of existing meter well as required, and all other appurtenances required in the Drawings and/or Specifications.
- B. All other new service tubing will be paid for under other Bid Item(s) as specified in Section 331113 – Water Distribution Piping.
- C. The cost of a curb stop shall include, but not be limited to, a service saddle, a corporation stop, a curb stop, a curb box with lid, a curb box plug, a concrete foundation, a concrete stabilizing block, traceable wire and related appurtenances (where required in the Drawings and/or Specifications), and detectable warning tape, and all other appurtenances required in the Drawings and/or Specifications.
- D. The cost of special landscaping restoration shall include, but not be limited, all work necessary to restore the described landscaping to its original condition or better.
- E. Restoration of Disturbed Area, Concrete Resurfacing, Crushed Stone Resurfacing, and Asphalt Paving shall be paid for under other Bid Items(s) specified elsewhere.

**24. Section 331216 – Water Utility Distribution Valves**

**Bid Item 8 – 6” M.J.T. Gate Valve with Box and Lid – Per Each**

**Bid Item 9 – 8” M.J.T. Gate Valve with Box and Lid – Per Each**

**Bid Item 19 – 6” M.J.T. Gate Valve with Box and Lid – Per Each**

- D. The cost for this work shall be paid for at the per each bid price for the size and type of valve specified.
- E. The cost of the valve shall include, but not be limited to, a valve, mechanical joint retainer restraints at mechanical joint connections, a valve box with lid, a concrete foundation, a valve box adaptor, a valve box plug, a concrete stabilizing block, traceable wire and related appurtenances (where required in the Drawings and/or Specifications), and detectable warning tape, and all other appurtenances required in the Drawings and/or Specifications.

- F. Restoration of Disturbed Area, Concrete Resurfacing, Crushed Stone Resurfacing, and Asphalt Paving shall be paid for under other Bid Items(s) specified elsewhere.

**25. Section 331219 – Water Utility Distribution Fire Hydrants**

**Bid Item 13 – Fire Hydrant Assembly, Complete – Per Each**

**Bid Item 20 – Fire Hydrant Assembly, Complete – Per Each**

- A. The cost for this work shall be paid for at the per each bid price for the fire hydrant assembly specified.
- B. The cost of a fire hydrant assembly shall include, but not be limited to, concrete thrust blocking, swivel hydrant tee, end of main line plug (as required), mechanical joint retainer restraints at mechanical joint connections, a gate valve (including a valve box with lid, a concrete foundation, a valve box adaptor, and a concrete stabilizing block), a fire hydrant (including plastic barrier, concrete thrust blocking, concrete foundations, and clean graded limestone), up to fifteen feet (20') of ductile iron pipe water line, all thread rods with coal tar coating, traceable wire and related appurtenances (where required in the Drawings and/or Specifications), detectable warning tape, and all other appurtenances required in the Drawings and/or Specifications.
- C. Restoration of Disturbed Area, Concrete Resurfacing, Crushed Stone Resurfacing, and Asphalt Paving shall be paid for under other Bid Items(s) specified elsewhere.

**26. Section 331300 – Disinfecting of Water Utility Distribution**

**Incidental**

- A. The cost of this work shall be included in the lump sum bid price(s) and/or unit bid price(s) for which disinfection is required.
- B. No additional compensation shall be made.

**Water for Flushing and Disinfection**

The Owner will provide to the Contractor, at no cost, up to four (4) times the volume of the water stored in the water lines installed in this Contract for use by the Contractor in flushing and disinfecting. Costs for volumes in excess of these amounts will be paid for by the Contractor to the Owner at the Leak Adjustment Rate or Bulk Water Rate, whichever is greater, published in the Water Purveyor's Tariff.

**27. Construction Layout Stakes and Surveying**

**Bid Item 2 – Construction Layout Stakes and Surveying – Lump Sum**

Brilliant Water & Sewer District  
2023 Water Line Replacement

- A. The contractor is responsible for all construction cost for this work shall be paid for at a lump sum bid price.
- B. No additional compensation shall be made.

**28. Additive Alternate 1 - Gilchrist Street Block 1200**

- A. The cost for this includes the 6-inch PVC C900 DR-14, 6-inch gate valves, hydrant removal, complete hydrant assembly, service connection (corporation stop, curb stop, and curb boxes), site work, excavation and backfill with finished grading, trench repair, and all other associated work and necessary appurtenances for a complete operable system.
- B. The contractor shall be responsible for locating all tie in points, existing utilities, and service lines necessary.
- C. For breakdown of all bid items within the additive alternate, reference the related specification section above.
- D. No additional compensation shall be made.

**29. General Specifications**

- A. The contract Specifications references provided attempt to outline the Contract Bid Item payment methodology for work to be performed. In the event of variation between the Bid Form and the preceding specification section measure and payment descriptions, the Contractor shall contact the Engineer before making any assumptions and proceeding with the Bid Item work or part thereof in question.

PART 2 - PRODUCTS - Not Used

PART 3 - EXECUTION - Not Used

END OF SECTION 012000

CAD FILE: R:\010\T10-11022.00-2023 Waterline Replacement Project-Brilliant Water And Sewer District-Drawing\6 PLAN & PROFILE - ALLEY BTW LABELLE & 2ND STA. 100+00 - 105+00.dwg  
 PLOT DATE/TIME: 10/25/2024 11:26 AM  
 USER: alexandra m. fechtko

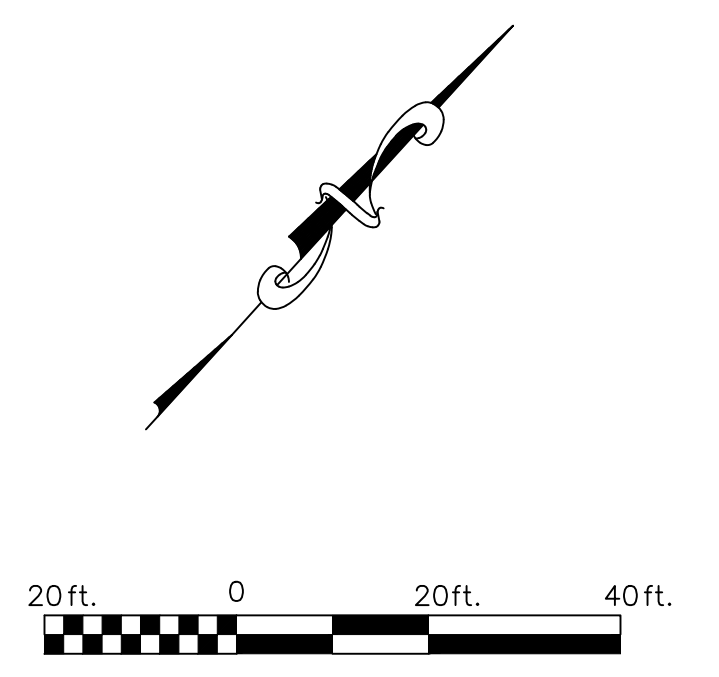
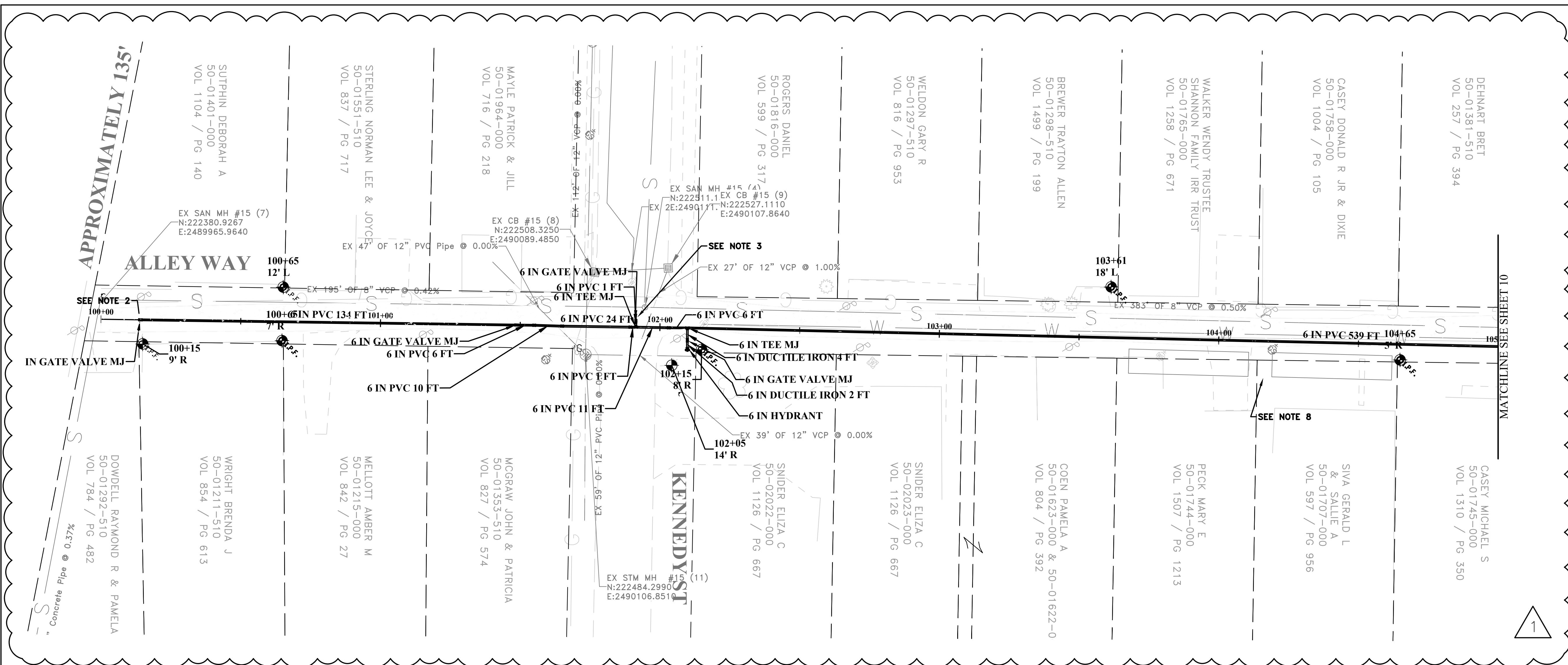

- NOTES:**
1. LOCATION OF EXISTING WATERLINE TO BE VERIFIED BY CONTRACTOR.
  2. FIELD LOCATE AND CONNECT TO SCHOOL'S EXISTING SERVICE LINE.
  3. CONTRACTOR TO CUT AND CAP EXISTING MAIN ON KENNEDY BEFORE CONSTRUCTION. EXCAVATE AND REMOVE EXISTING MAIN AS NEW MAIN IS INSTALLED. TIE NEW MAIN INTO EXISTING MAIN AFTER COMPLETION.
  4. ABANDON IN PLACE EXISTING LINE ONCE CONSTRUCTION IS COMPLETE
  5. SEE SHEET D1 FOR TRENCH REPAIR DETAILS
  6. SEE SHEET D1 FOR TYPICAL WATERMAIN THRUST BLOCKING DETAILS
  7. SEE GENERAL NOTES
  8. CONTRACTOR TO RECONNECT SERVICE LINES WITHOUT DISTURBING NEW CONSTRUCTION PADS

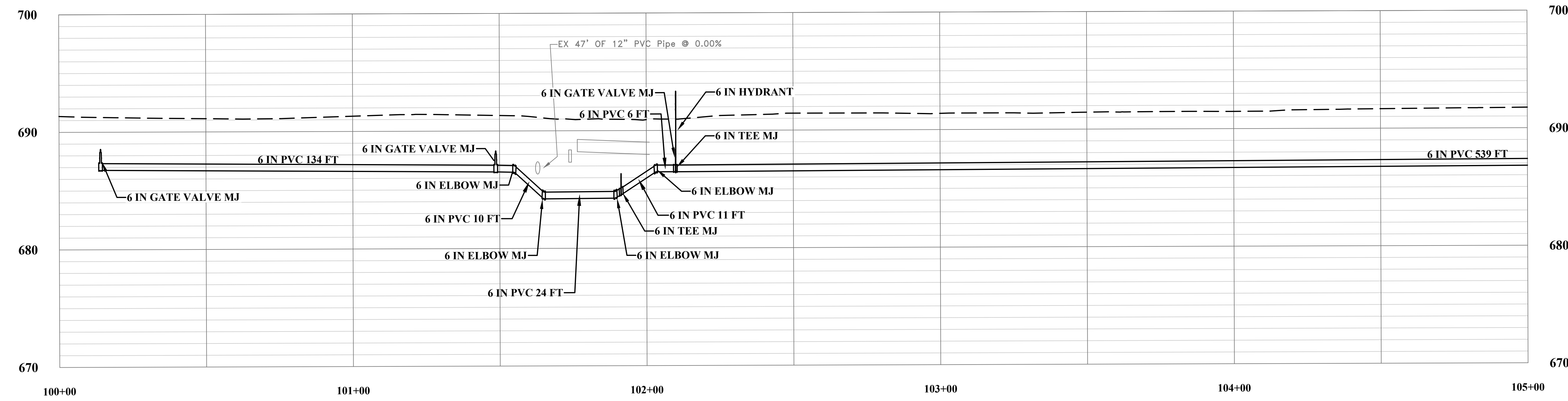

NO.	BY	DATE	DESCRIPTION
1	AMF	25OCT2024	ADDENDUM 3

SCALE: AS NOTED	DATE: 18MAY2023
DRAWN: AMF	CHECKED: ###
APPROVED: JCC	DATE: 10CT2024
SURVEY DATE:	
SURVEY BY:	
FIELD BOOK No.:	

**THRASHER**

400 3rd STREET SE  
 CANTON, OHIO 44702  
 www.thrashereng.com

PHONE (330)-451-2042  
 FAX (330)-451-2043

PHASE No.	
CONTRACT No.	
PROJECT No.	<b>T10-11022</b>

**BRILLIANT WATER AND SEWER DISTRICT - 2023 WATERLINE REPLACEMENT**

**PLAN & PROFILE - ALLEY BTW LABELLE & 2ND STA 100+00 - 105+00**

SHEET No. **9**

CAD FILE: R:\010\T10-11022.00-2023 Waterline Replacement Project-Brilliant Water And Sewer District-Drawing\7 PLAN & PROFILE - ALLEY BTW LABELLE & 2ND STA. 105+00 - 110+00.dwg  
 PLOT DATE/TIME: 10/25/2024 11:27 AM  
 USER: alexandria m. fechtko

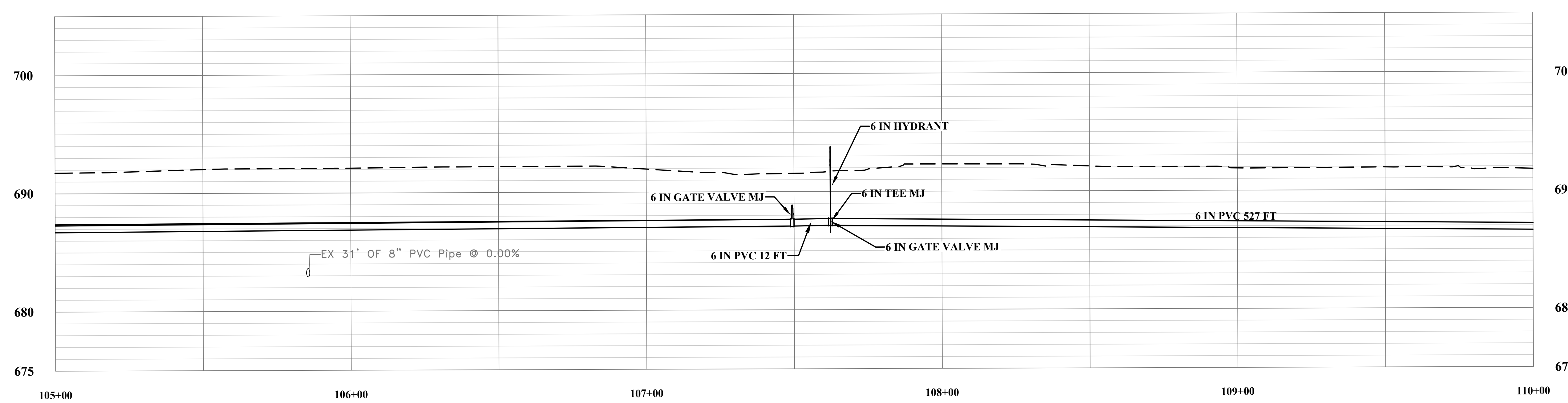
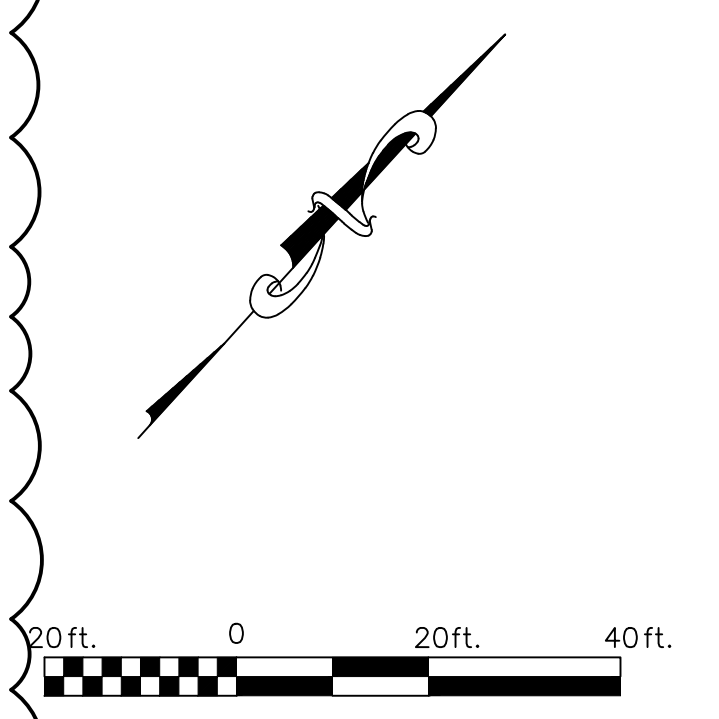
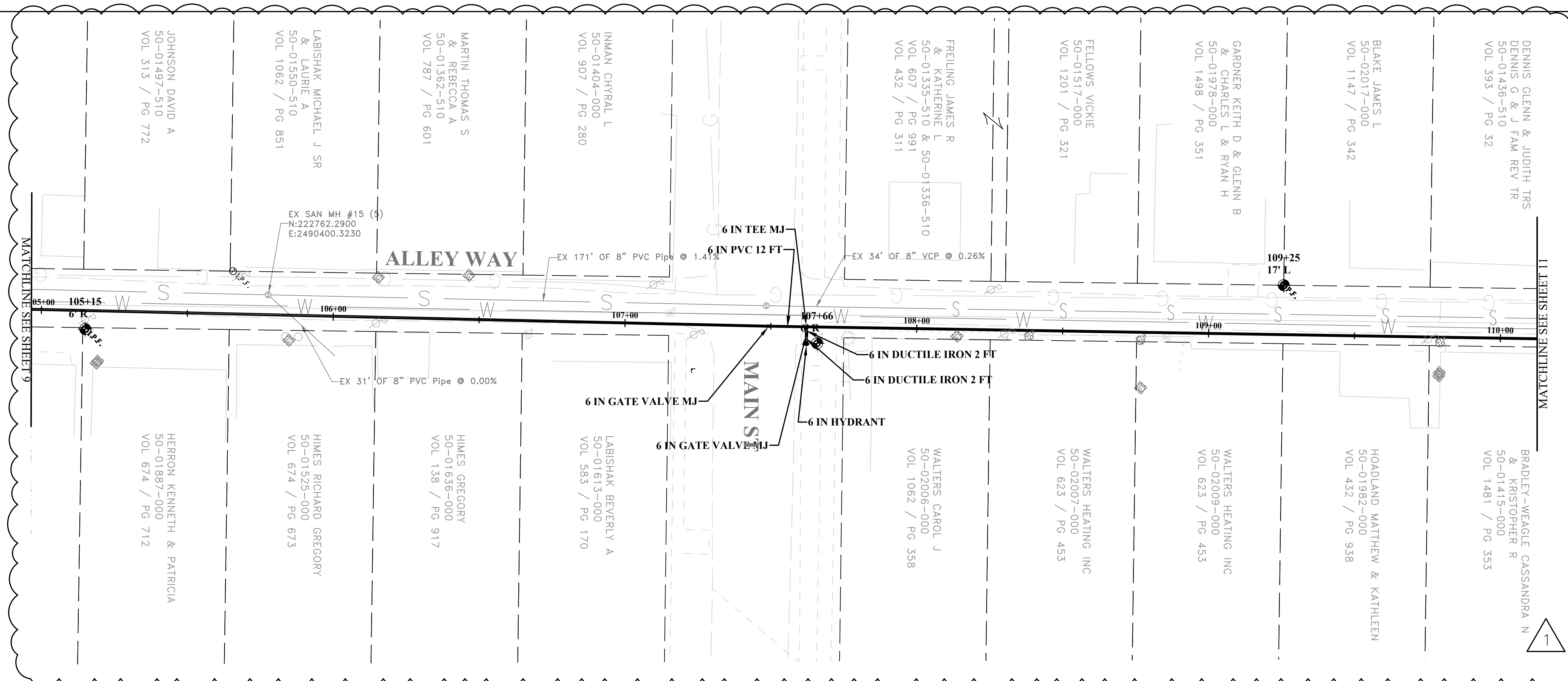

- NOTES:
1. LOCATION OF EXISTING WATERLINE TO BE VERIFIED BY CONTRACTOR
  2. EXCAVATE AND REMOVE EXISTING WATER MAIN AS NEW WATER MAIN IS INSTALLED.
  3. SEE SHEET D1 FOR TRENCH REPAIR DETAILS
  4. SEE SHEET D1 FOR TYPICAL WATERMAIN THRUST BLOCKING DETAILS
  5. SEE GENERAL NOTES.

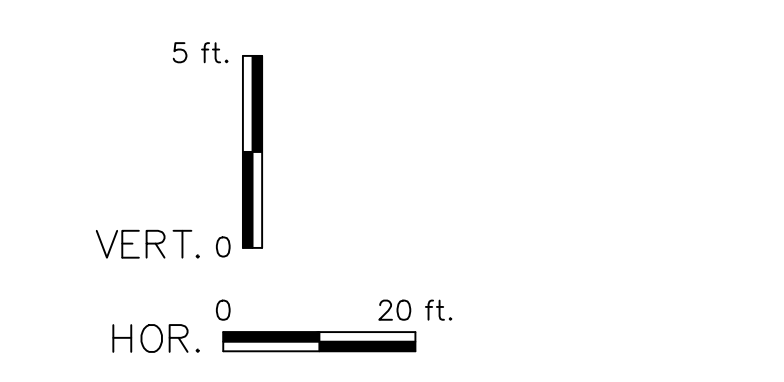

NO.	BY	DATE	DESCRIPTION
1	AMF	25OCT2024	ADDENDUM 3

SCALE: AS NOTED
DRAWN: AMF
CHECKED: ###
APPROVED: JCC
SURVEY DATE:
SURVEY BY:
FIELD BOOK No.:

DATE: 18MAY2023
DATE: ###
DATE: 10CT2024

**THRASHER**

400 3rd STREET SE  
CANTON, OHIO 44702  
www.thrashereng.com

PHONE (330)-451-2042  
FAX (330)-451-2043

PHASE No.
CONTRACT No.
PROJECT No.

**BRILLIANT WATER AND SEWER DISTRICT -  
2023 WATERLINE REPLACEMENT**

**PLAN & PROFILE - ALLEY BTW LABELLE &  
2ND STA 105+00 - 110+00**

SHEET No.  
**10**

USER: alexandria m. fechtko  
 PLOT DATE/TIME: 10/25/2024 11:29 AM  
 CAD FILE: R:\010\T10-11022.00-2023 Waterline Replacement Project-Brilliant Water And Sewer District-Drawing\8 PLAN & PROFILE - ALLEY BTW LABELLE & 2ND STA 110+00 - 113+10.dwg

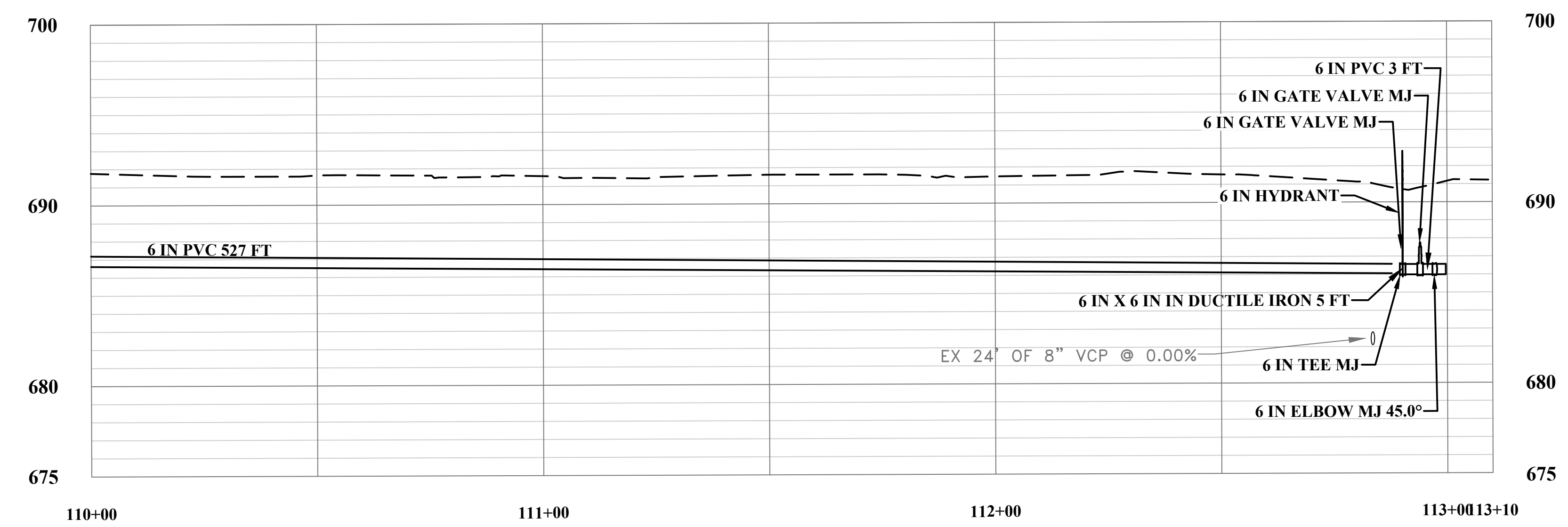
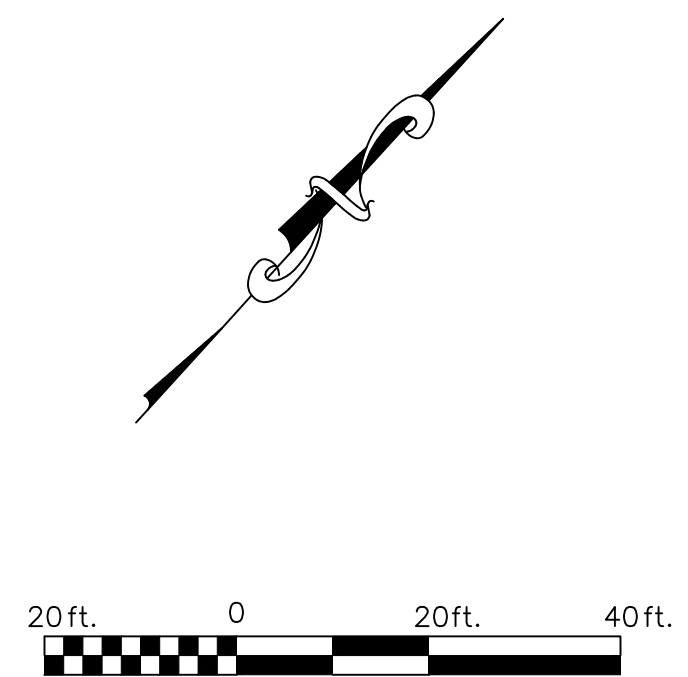
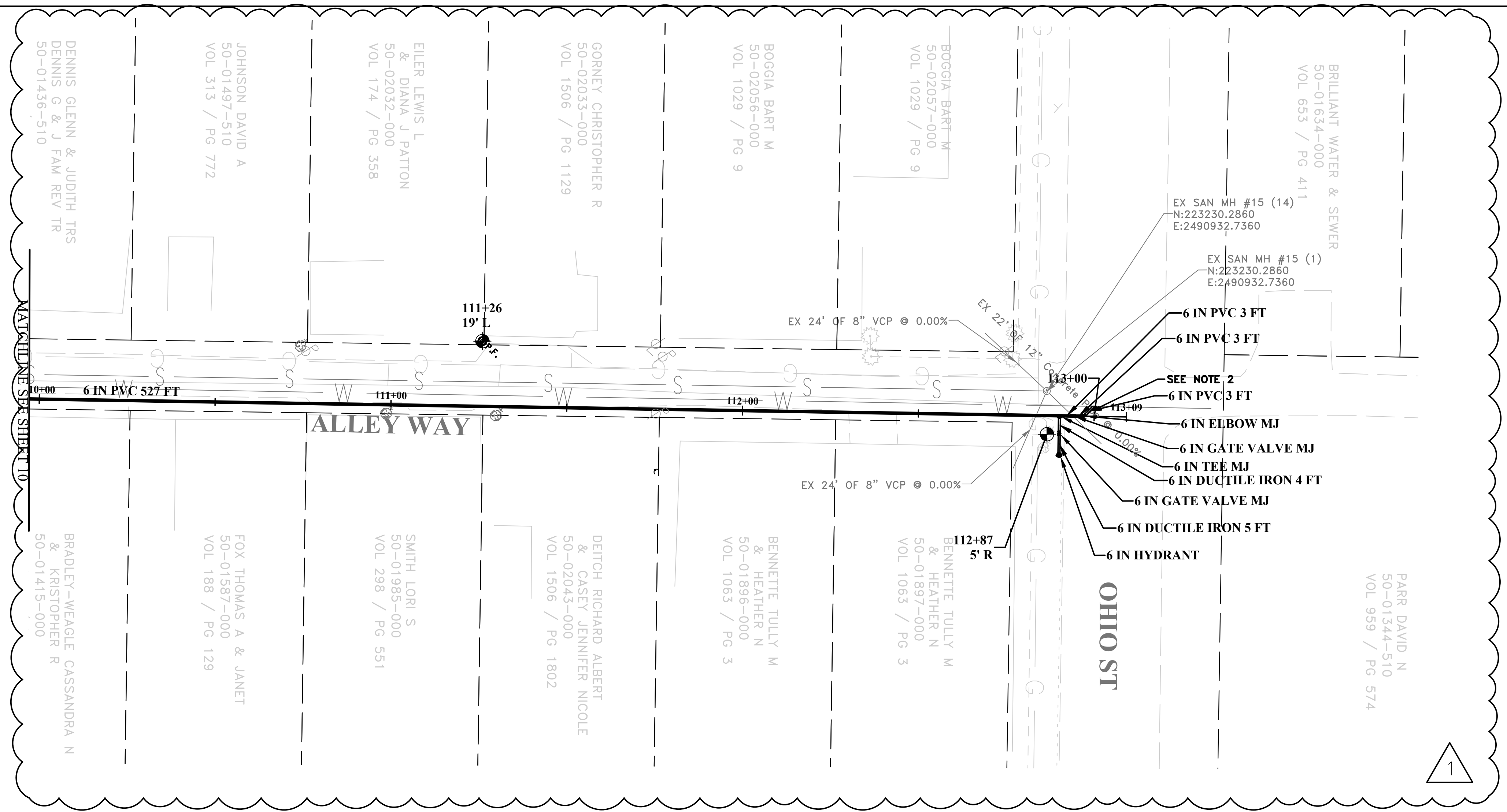

- NOTES:
1. LOCATION OF EXISTING WATERLINE TO BE VERIFIED BY CONTRACTOR.
  2. CONTRACTOR IS TO CUT AND CAP EXISTING WATER MAIN IN ALLEY BEFORE CONSTRUCTION. EXCAVATE AND REMOVE EXISTING WATER MAIN AS NEW WATER MAIN IS INSTALLED. THE NEW WATER MAIN IS TO EXISTING WATER MAIN IN OHIO STREET AFTER COMPLETION.
  3. ABANDON IN PLACE EXISTING LINE ONCE CONSTRUCTION IS COMPLETE
  4. SEE SHEET D1 FOR TRENCH REPAIR DETAILS
  5. SEE SHEET D1 FOR TYPICAL WATERMAIN THRUST BLOCKING DETAILS
  6. SEE GENERAL NOTES



THE INFORMATION CONTAINED HEREIN IS THE SOLE PROPERTY OF THE THRASHER GROUP INC. REPRODUCTION OF THESE DOCUMENTS IN WHOLE OR IN PART, FOR ANY REASON WITHOUT PRIOR WRITTEN PERMISSION, IS STRICTLY PROHIBITED. COPYRIGHT © 2022 THE THRASHER GROUP INC.			
NO.	BY	DATE	DESCRIPTION
1	AMF	25OCT2024	ADDENDUM 3

SCALE: AS NOTED	
DRAWN: AMF	DATE: 18MAY2023
CHECKED: ###	DATE: ###
APPROVED: JCC	DATE: 10CT2024
SURVEY DATE:	
SURVEY BY:	
FIELD BOOK No.:	

**THRASHER**  
 400 3rd STREET SE  
 CANTON, OHIO 44702  
 www.thrashereng.com  
 PHONE (330)-451-2042 FAX (330)-451-2043

PHASE No.
CONTRACT No.
PROJECT No.
<b>T10-11022</b>

**BRILLIANT WATER AND SEWER DISTRICT - 2023 WATERLINE REPLACEMENT**  
**PLAN & PROFILE - ALLEY BTW LABELLE & 2ND STA 110+00 - 113+10**

SHEET No.  
11

USER: alexandra.m. fechtko  
 PLOT DATE/TIME: 10/24/2024 8:08 AM  
 CAD FILE: R:\010\T10-11022-00-2023 Waterline Replacement Project-Brilliant Water And Sewer District-Drawing\22 PLAN & PROFILE - OHIO ST. AND 5TH ST. STA 299+00 - 305+00.dwg  
 PROJECT: Brilliant Water And Sewer District - Drawing\22 PLAN & PROFILE - OHIO ST. AND 5TH ST. STA 299+00 - 305+00.dwg

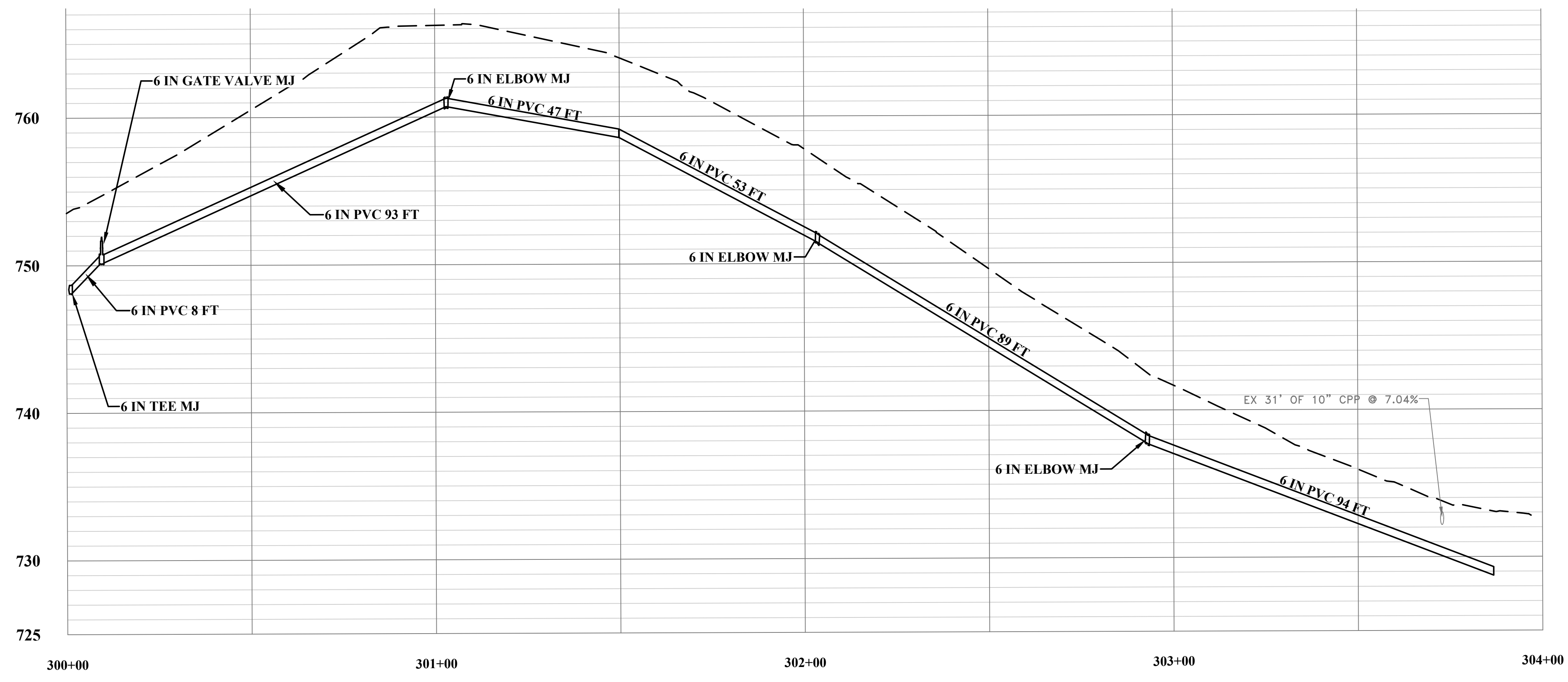
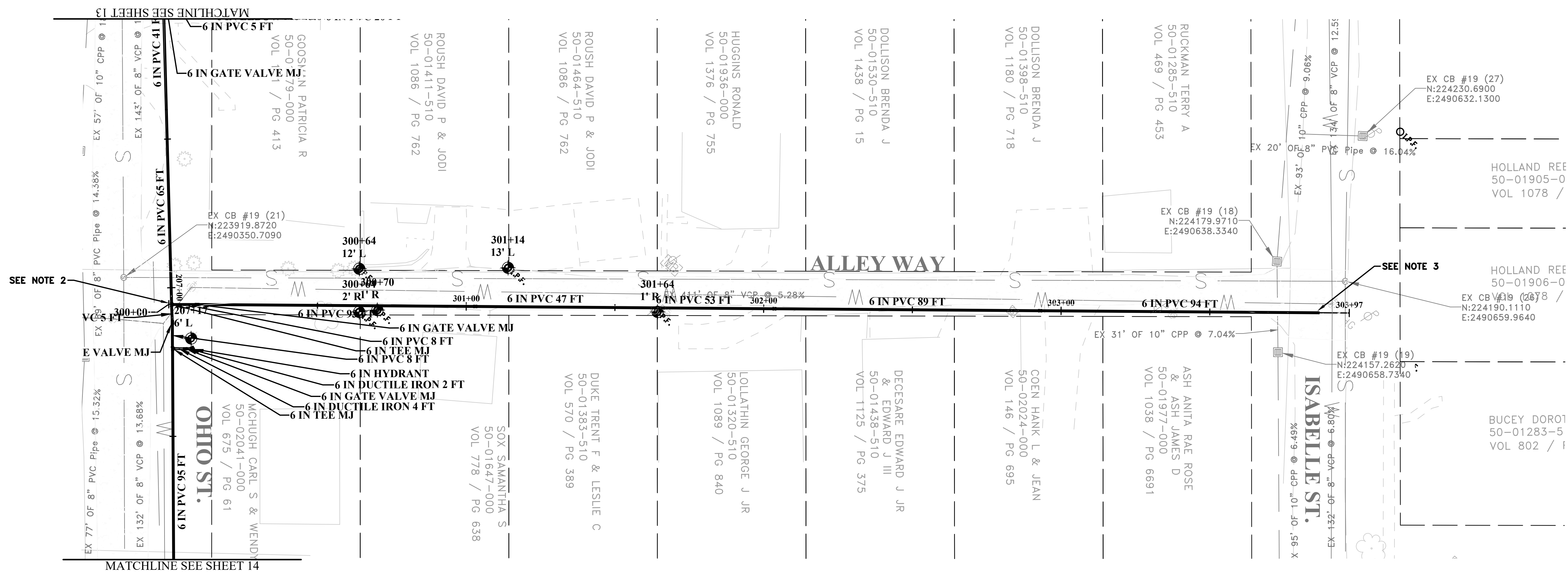

- NOTES:**
1. LOCATION OF EXISTING WATERLINE TO BE VERIFIED BY CONTRACTOR
  2. THE INSTALLATION OF THE NEW MAIN THROUGH THE ALLEY IS REMOVE AND REPLACE THE EXISTING WATER MAIN.
  3. TIE NEW MAIN INTO EXISTING VALVE
  4. SEE GENERAL NOTES
  5. EXCAVATE AND REMOVE EXISTING WATER MAIN AS NEW WATER MAIN IS INSTALLED IF NECESSARY.
  6. SEE SHEET D1 FOR TRENCH REPAIR DETAILS
  7. SEE SHEET D1 FOR TYPICAL WATERMAIN THRUST BLOCKING DETAILS
  8. SEE GENERAL NOTES

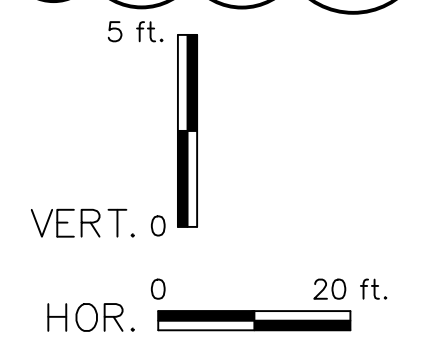

NO.	BY	DATE	DESCRIPTION
1	AMF	24OCT2024	ADDENDUM 3

SCALE: AS NOTED	
DRAWN: AMF	DATE: 18MAY2023
CHECKED: ###	DATE: ###
APPROVED: JCC	DATE: 10CT2024
SURVEY DATE:	
SURVEY BY:	
FIELD BOOK No.:	

**THRASHER**

400 3rd STREET SE  
 CANTON, OHIO 44702  
 www.thrashereng.com

PHONE (330)-451-2042  
 FAX (330)-451-2043

PHASE No.	
CONTRACT No.	
PROJECT No.	T10-11022

**BRILLIANT WATER AND SEWER DISTRICT -**  
**2023 WATERLINE REPLACEMENT**  
**PLAN & PROFILE - OHIO ST. AND 5TH ST.**  
**STA 300+00 - 304+00**

SHEET No.  
**15**

USER: alexandra m. fecho  
 PLOT DATE/TIME: 10/24/2024 8:09 AM  
 CAD FILE: R:\010\T10-11022.00-2023 Waterline Replacement Project-Brilliant Water And Sewer District-Drawing\26 PLAN & PROFILE - GREEN RD AND LABELLE ST STA 600+00- 604+50.dwg

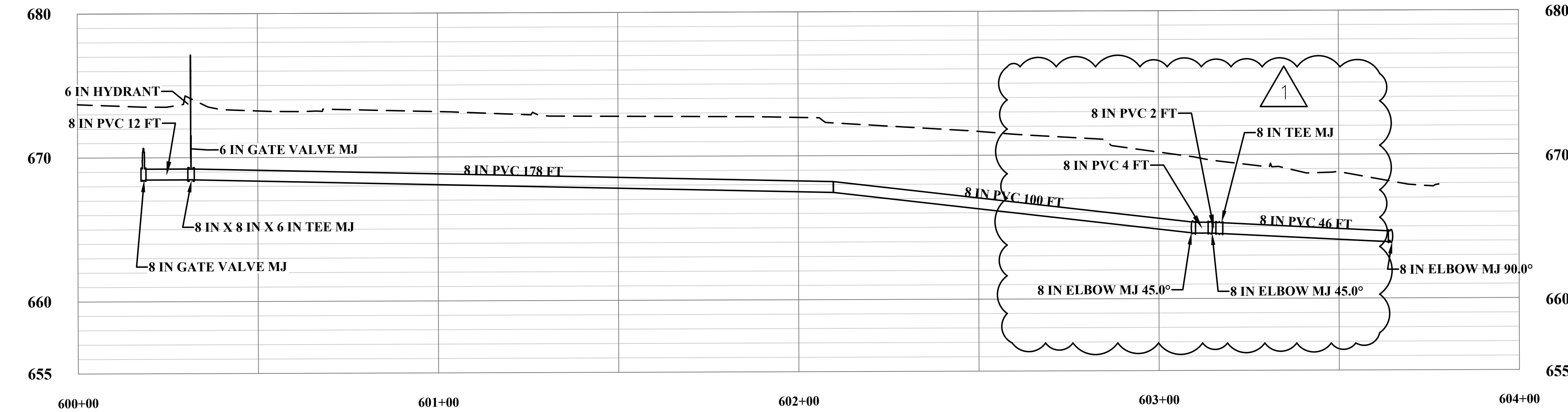
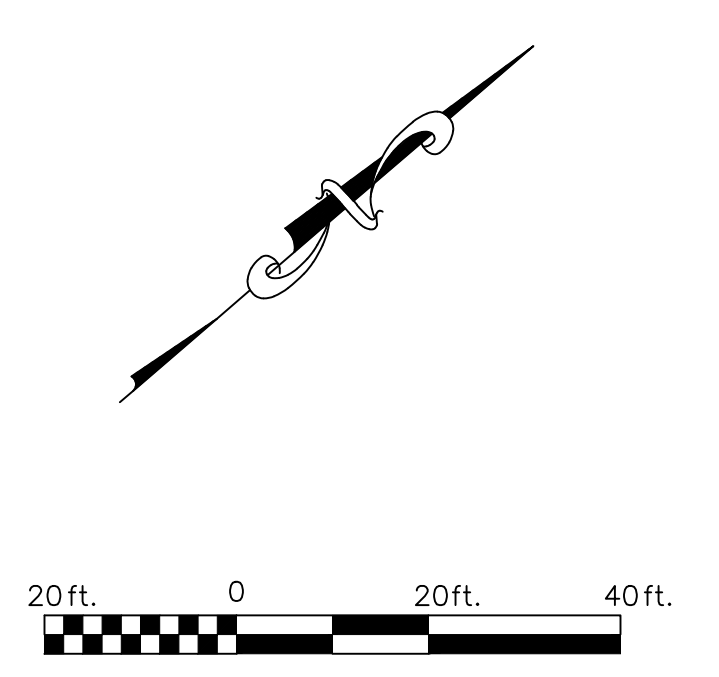
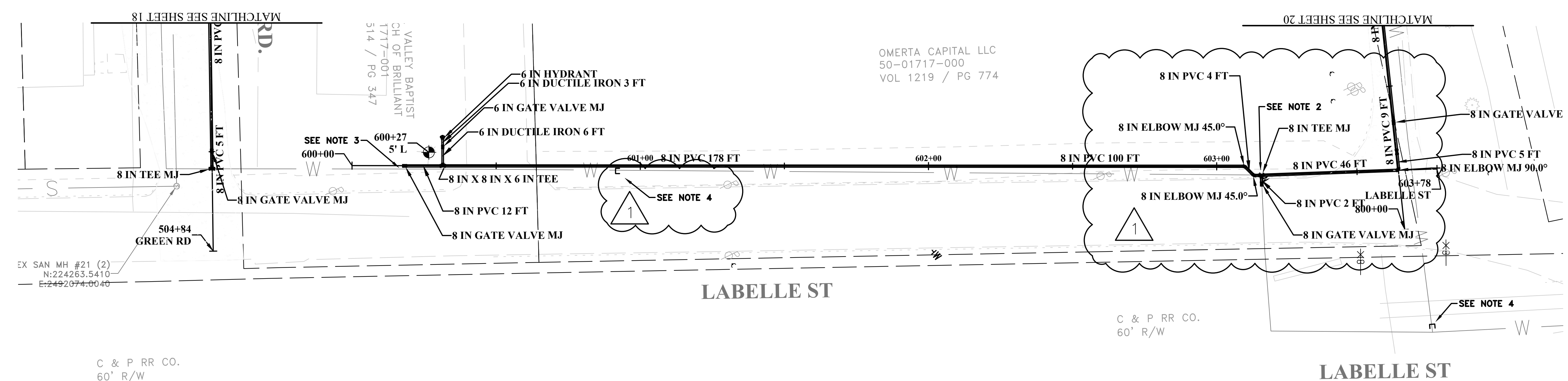

- NOTES:
1. LOCATION OF EXISTING WATERLINE TO BE VERIFIED BY CONTRACTOR
  2. CONNECT TO EXISTING TEE AND VALVES.
  3. CUT, CAP AND ABANDON EXISTING WATER MAIN IN LABELLE. CONNECT TO EXISTING WATER MAIN IN LABELLE STREET.
  4. ABANDON IN PLACE EXISTING LINE ONCE CONSTRUCTION IS COMPLETE
  5. SEE SHEET D1 FOR TRENCH REPAIR DETAILS
  6. SEE SHEET D1 FOR TYPICAL WATERMAIN THRUST BLOCKING DETAILS

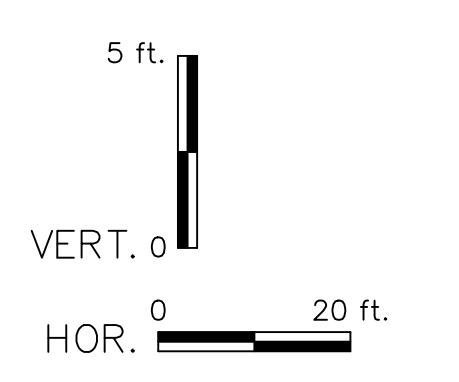

THE INFORMATION CONTAINED HEREIN IS THE SOLE PROPERTY OF THE THRASHER GROUP INC. REPRODUCTION OF THESE DOCUMENTS IN WHOLE OR IN PART, FOR ANY REASON WITHOUT PRIOR WRITTEN PERMISSION, IS STRICTLY PROHIBITED. COPYRIGHT © 2022 THE THRASHER GROUP INC.			
NO.	BY	DATE	DESCRIPTION
1	AMF	24OCT2024	ADDENDUM 3

SCALE: AS NOTED	
DRAWN: AMF	DATE: 18MAY2023
CHECKED: ###	DATE: ###
APPROVED: JCC	DATE: 10CT2024
SURVEY DATE:	
SURVEY BY:	
FIELD BOOK No.:	

**THRASHER**

400 3rd STREET SE  
CANTON, OHIO 44702  
www.thrashereng.com

PHONE (330)-451-2042      FAX (330)-451-2043

PHASE No.	
CONTRACT No.	
PROJECT No.	T10-11022

**BRILLIANT WATER AND SEWER DISTRICT - 2023 WATERLINE REPLACEMENT**

**PLAN & PROFILE - GREEN RD AND LABELLE ST STA 600+00- 604+50**

SHEET No.

19



USER: alexandra.m. fechtko  
 LAYOUT: D2 GENERAL DETAILS  
 PLOT DATE/TIME: 10/25/2024 11:29 AM  
 CAD FILE: R:\010\T10-11022.00-2023 Waterline Replacement Project-Brilliant Water And Sewer District-Drawing\35 GENERAL DETAILS.dwg

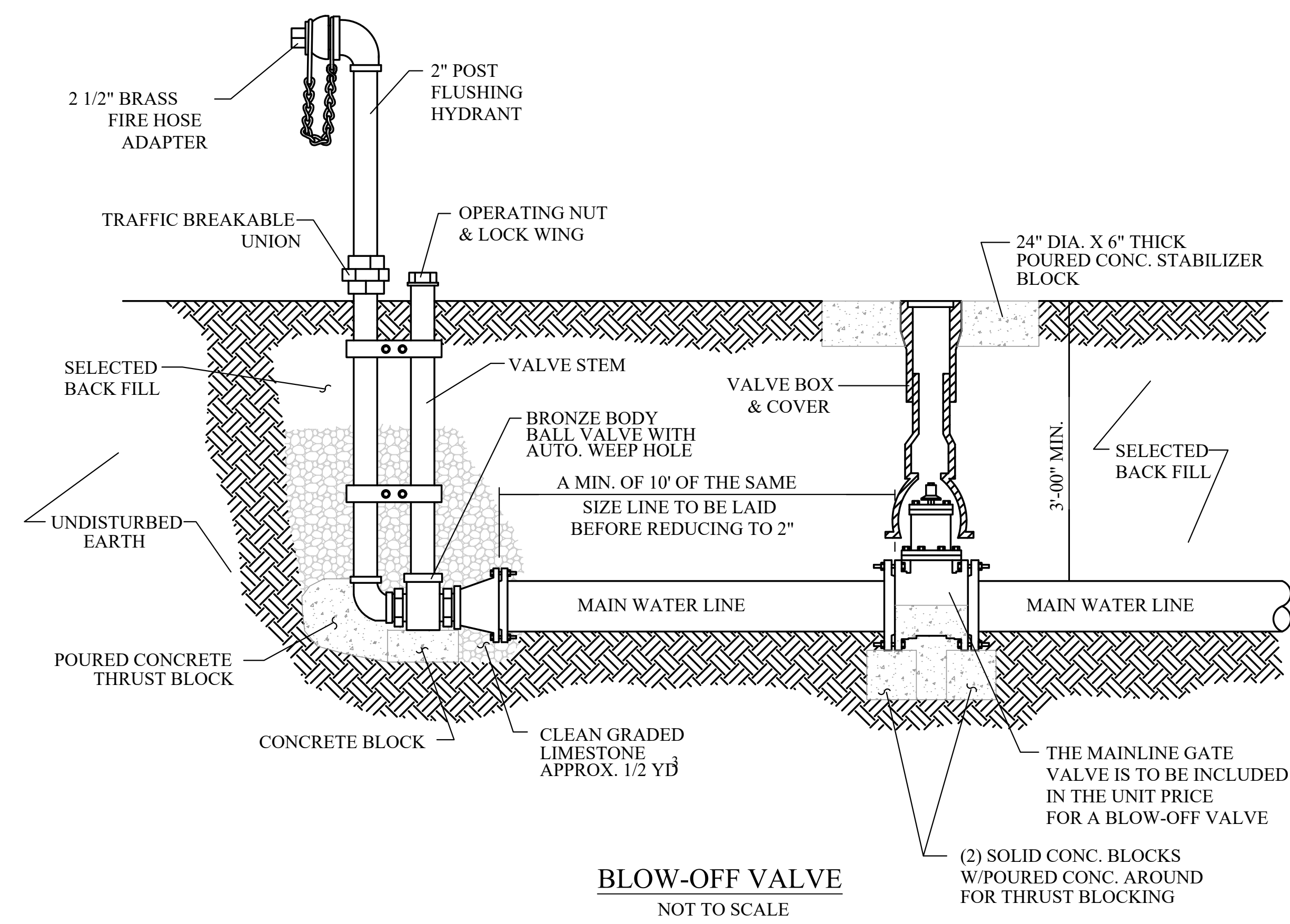

**BLOW-OFF VALVE**  
NOT TO SCALE

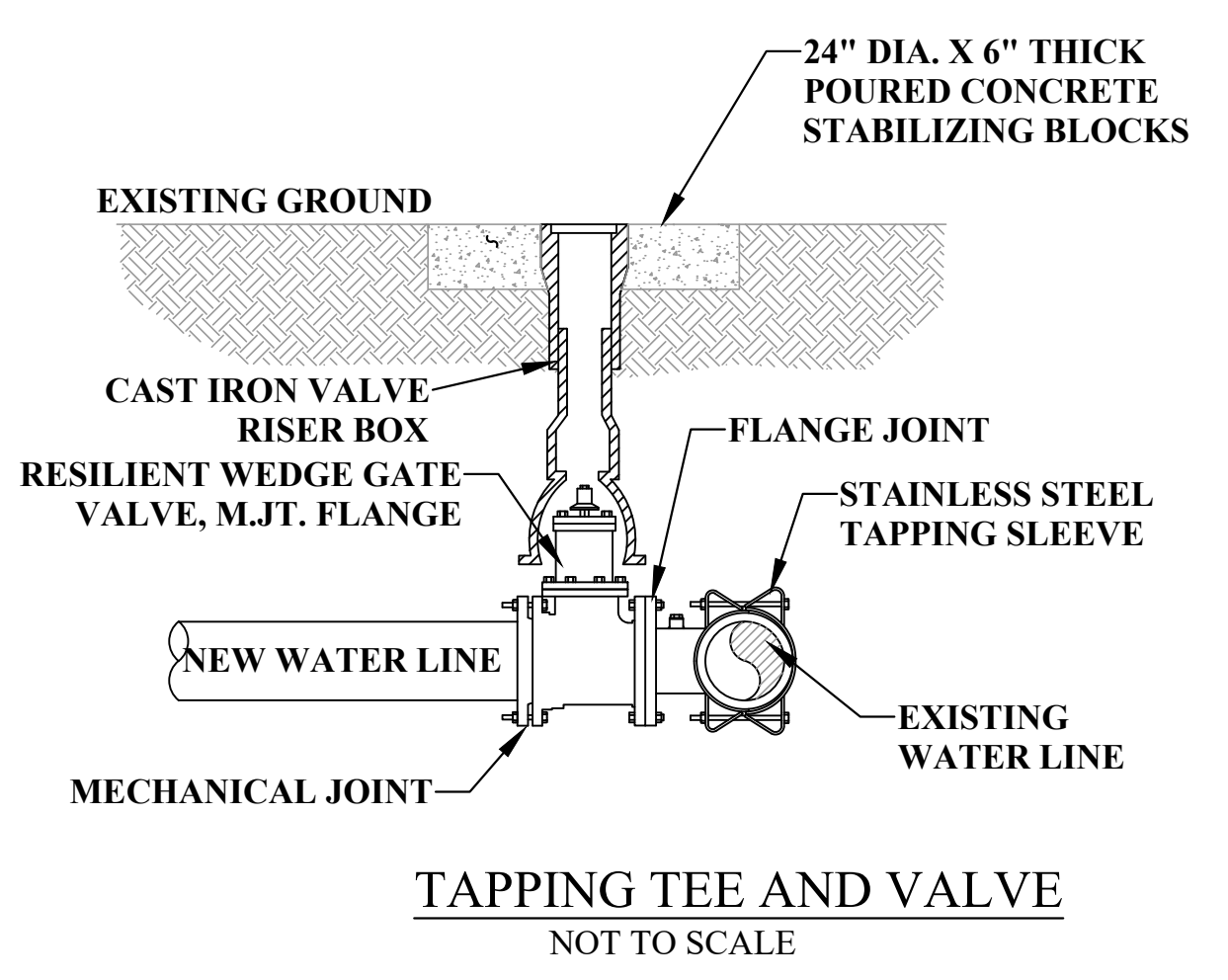

**TAPPING TEE AND VALVE**  
NOT TO SCALE

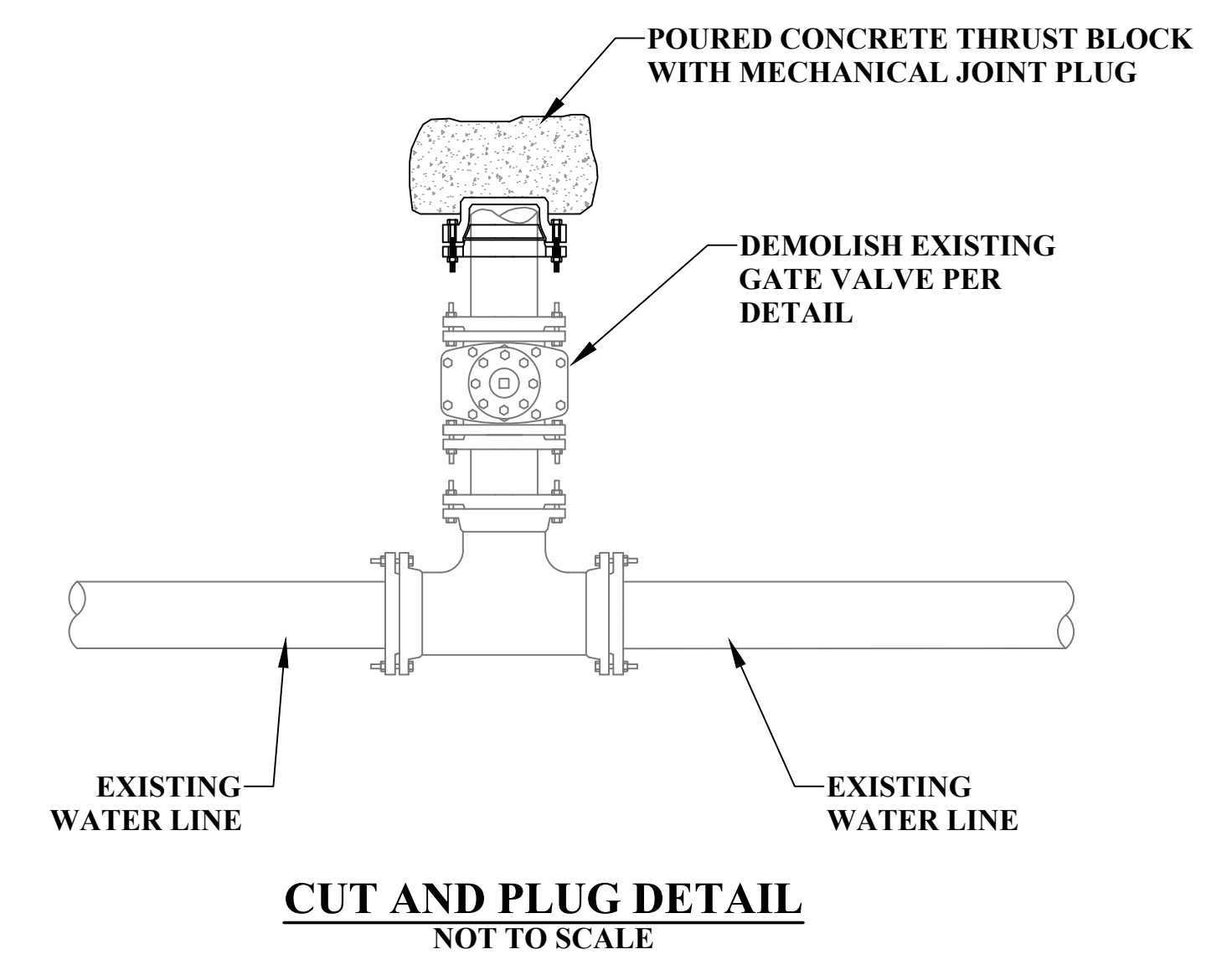

**CUT AND PLUG DETAIL**  
NOT TO SCALE

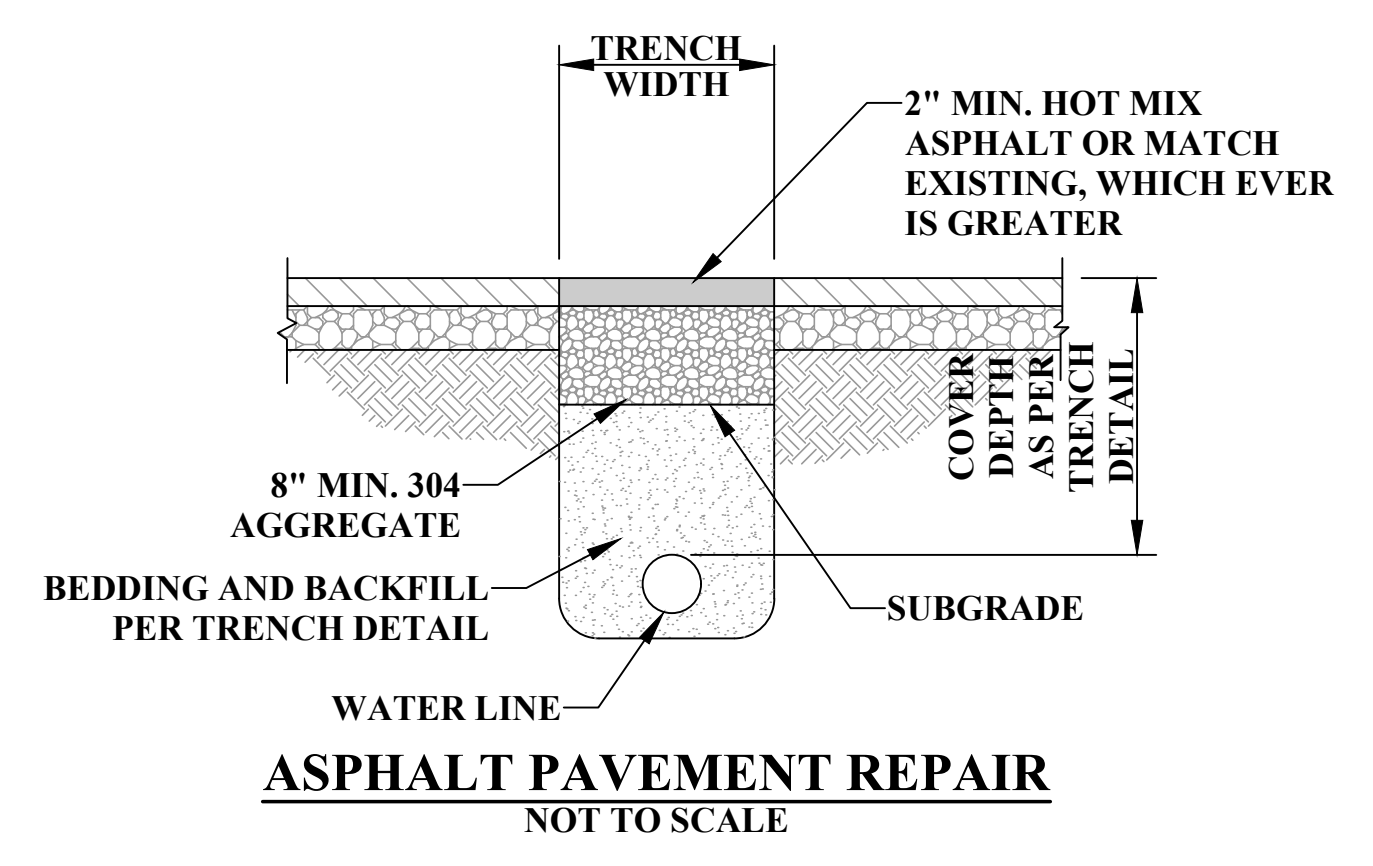

**ASPHALT PAVEMENT REPAIR**  
NOT TO SCALE

NOTES: 1) SEAL ALL EXPOSED JOINTS WITH ASPHALT CEMENT GRADE AC-20 OR APPROVED EQUAL.

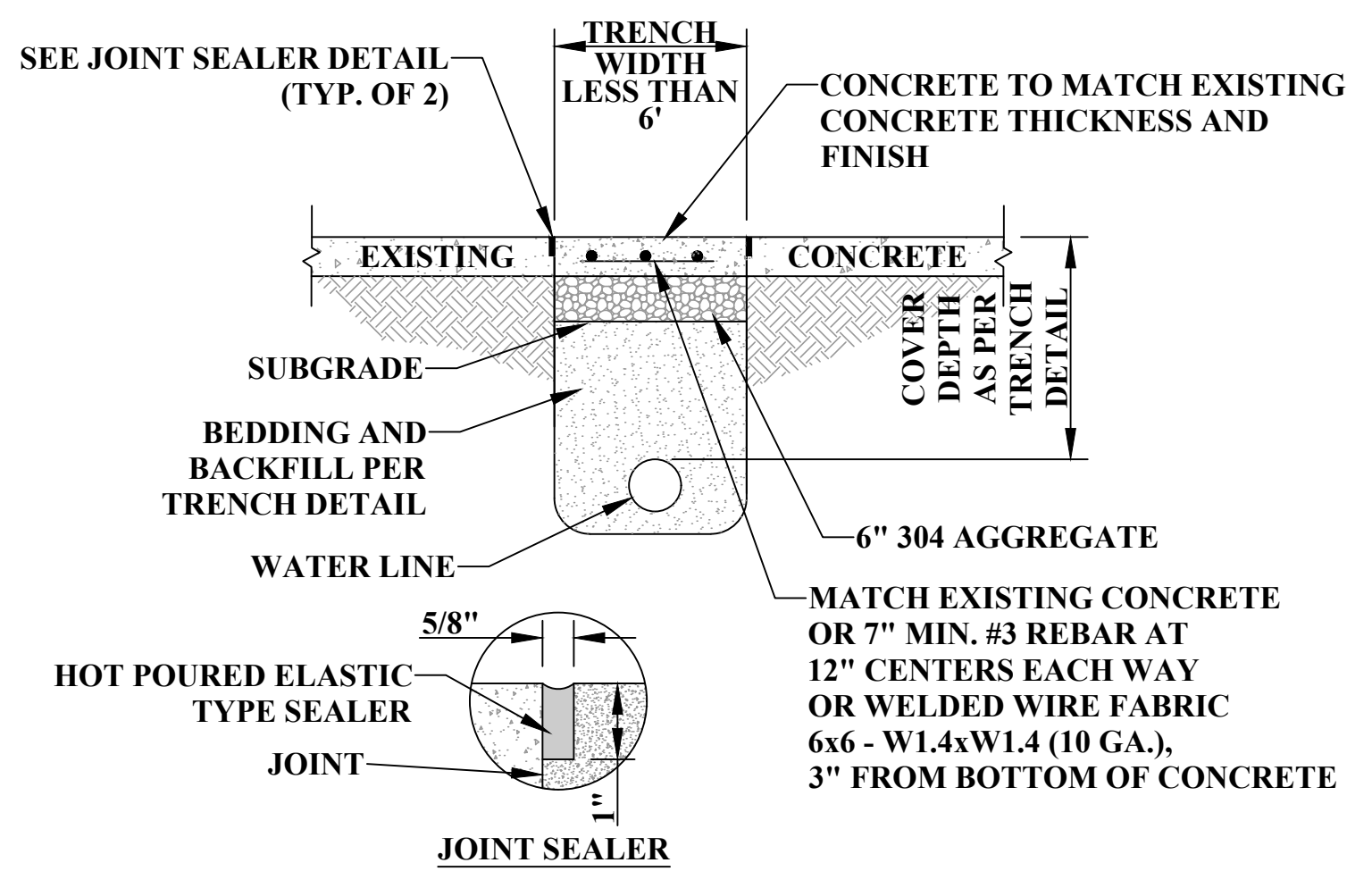

**CONCRETE PAVEMENT REPAIR**  
NOT TO SCALE

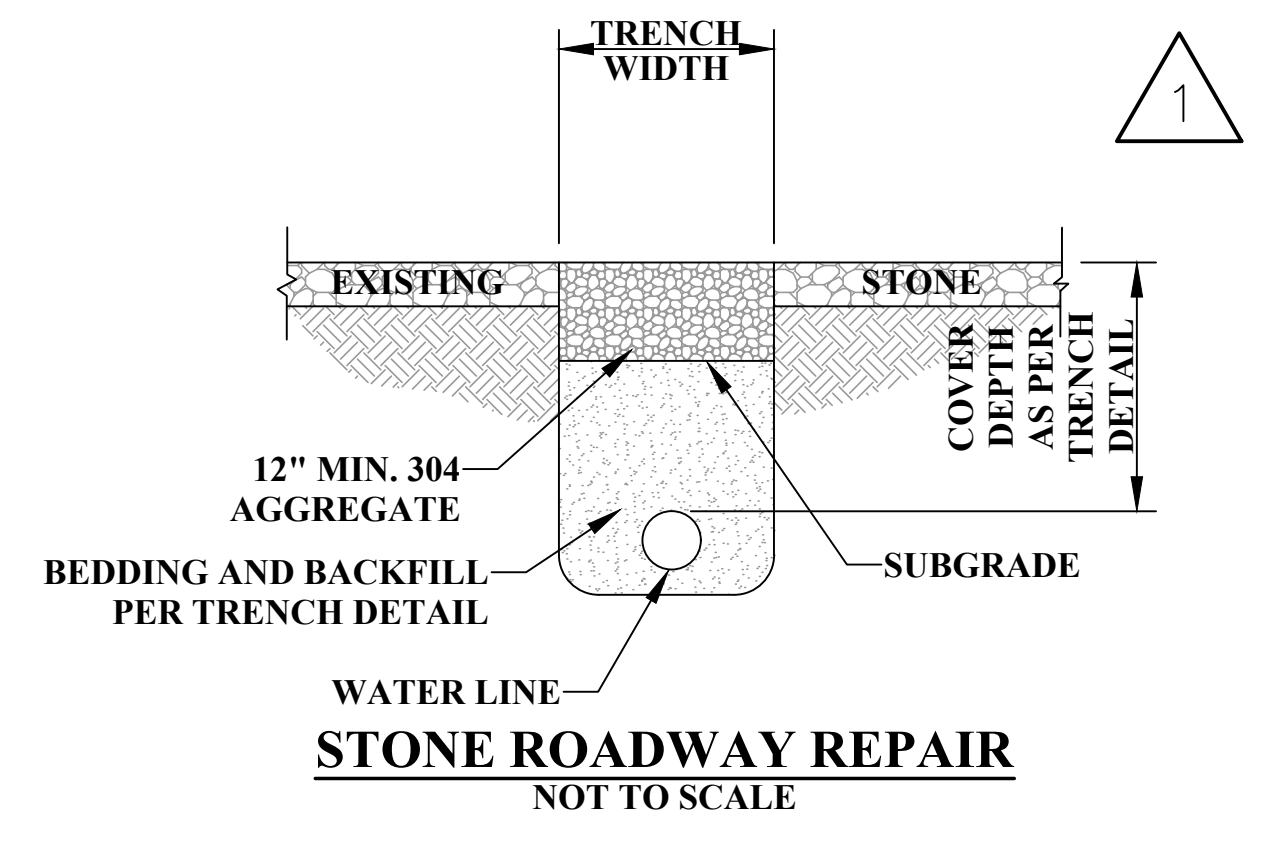

**STONE ROADWAY REPAIR**  
NOT TO SCALE

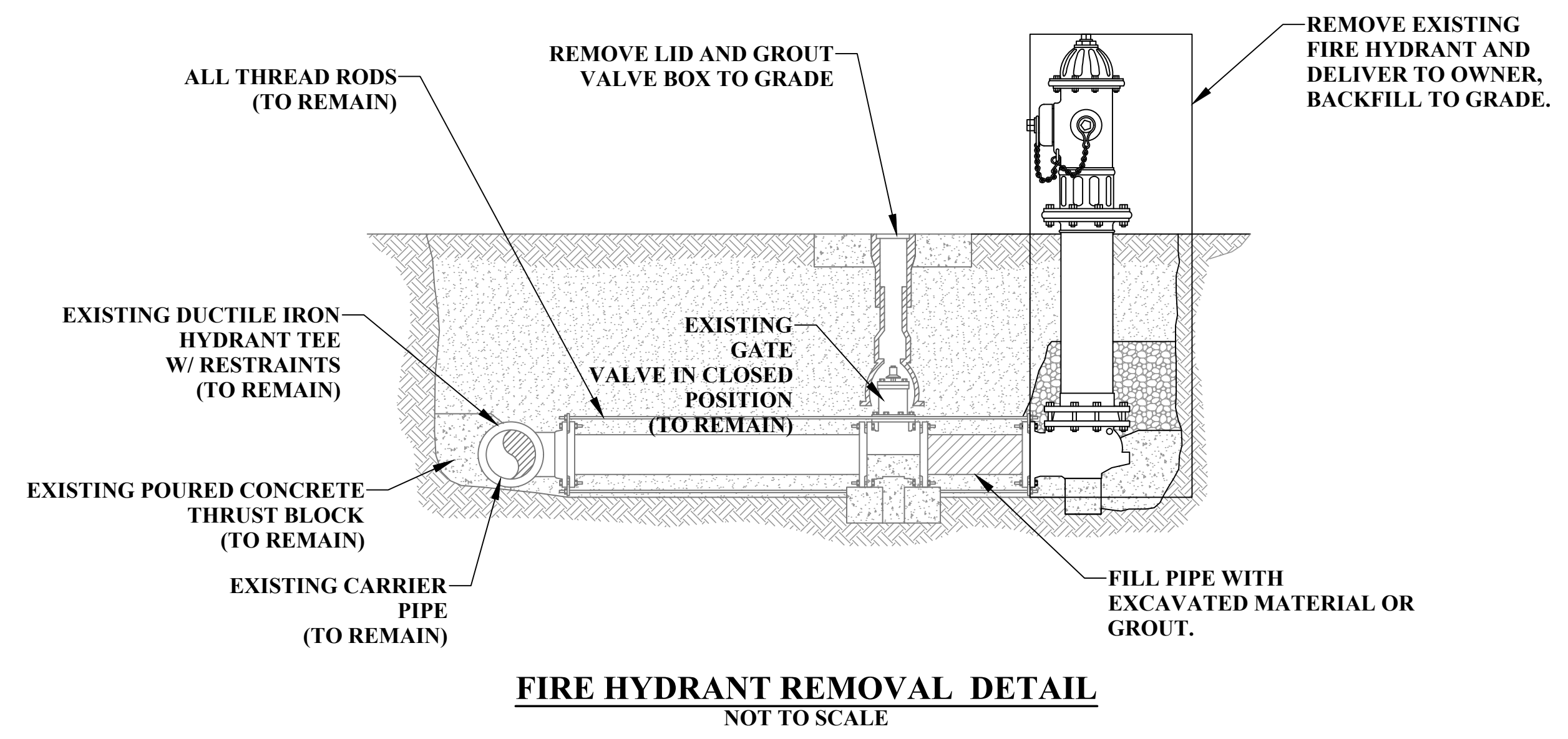

**FIRE HYDRANT REMOVAL DETAIL**  
NOT TO SCALE

THE INFORMATION CONTAINED HEREIN IS THE SOLE PROPERTY OF THE THRASHER GROUP INC. REPRODUCTION OF THESE DOCUMENTS IN WHOLE OR IN PART, FOR ANY REASON WITHOUT PRIOR WRITTEN PERMISSION, IS STRICTLY PROHIBITED. COPYRIGHT © 2022 THE THRASHER GROUP INC.			
1	AMF	25OCT2024	ADDENDUM 3
NO.	BY	DATE	DESCRIPTION

SCALE: AS NOTED	DATE: 18MAY2023
DRAWN: AMF	DATE: ###
CHECKED: ###	DATE: 10CT2024
APPROVED: JCC	
SURVEY DATE:	
SURVEY BY:	
FIELD BOOK No.:	

**THRASHER**

400 3rd STREET SE  
 CANTON, OHIO 44702  
 www.thrashereng.com

PHONE (330)-451-2042  
 FAX (330)-451-2043

PHASE No.	
CONTRACT No.	
PROJECT No.	<b>T10-11022</b>

**BRILLIANT WATER AND SEWER DISTRICT -**  
**2023 WATERLINE REPLACEMENT**  
**GENERAL DETAILS**

SHEET No.  
**D2**