



COMPLEX PROJECTS  
REQUIRE RESOLVE  
**THRASHER'S GOT IT**

**TOWN OF ELIZABETH  
WIRT COUNTY, WEST VIRGINIA**

**CONTRACT #1 - TUCKER CREEK ROAD WATERLINE EXTENSION**

**ADDENDUM #1**

**JULY 28, 2023**

**THRASHER PROJECT #010-10193**

TO WHOM IT MAY CONCERN:

A Pre-Bid Conference was held on Tuesday, July 25, 2023 on the above-referenced project, a copy of the sign in sheet is included in this Addendum. The following are clarifications and responses to questions posed by contractors for the above reference project.

**A. GENERAL**

1. Bids will be received by the Town of Elizabeth 73 Town Hall Lane, Elizabeth, WV 26143. Bids shall be mailed, or hand delivered before the bid opening on **Thursday, August 17, 2023 at 1:00 pm**. The bid opening shall take place at the Elizabeth Wirt Volunteer Fire Department located at 91 Schoolview Street, Elizabeth, WV 26143.

**B. SPECIFICATIONS**

1. NOT APPLICABLE

**C. DRAWINGS**

1. NOT APPLICABLE

**D. QUESTIONS AND RESPONSES**

**1. QUESTION**

Are there pipe profiles for the directional drill and bore and jack sections?

**RESPONSE**

No, minimum cover is required for all pipe installation.

**2. QUESTION**

Can you provide a detail for the WVDOH Type “C” Trench Repair?

**RESPONSE**

Yes, refer to attached Type “C” Trench Repair Detail included with this Addendum No. 1.

**3. QUESTION**

Is there a pay item for road berm?

**RESPONSE**

Road berm restoration shall be included in the linear foot price for Type “C” Trench Repair, Bid Item 17.

**4. QUESTION**

Can the service tap required for Customer 15 on Sheet 3 be moved outside of the directional drill?

**RESPONSE**

Yes, the meter pit installation and service tap required for Customer 15 can be located at Station 50+00 and installed on the proposed 6” PVC C-900 DR-14 waterline.

**5. QUESTION**

Is Rock Lined Ditch required?

**RESPONSE**

Rock Lined Ditch will be required on slopes greater than 5% and shall be included in the costs for Reclamation of Disturbed Area Bid Item 19.

**6. QUESTION**

Is joint sealant required for asphalt in the WVDOH ROW?

**RESPONSE**

Yes, WVDOH requires all asphalt and concrete joints be sealed with hot poured rubber joint sealer.

**7. QUESTION**

Can HDPE be used as an alternative to PVC?

**RESPONSE**

Yes. HDPE pipe may be substituted for PVC pipe (Bid Item 4) subject to Engineer approval and as follows:

- 6” PVC DR 18 (specified) to 8” HDPE DR-11 (substitute)  
\*Due to hydraulic constraints all specified 6” PVC piping is required to be upsized to 8” HDPE piping

All HDPE pipe must conform to requirements set forth in Section 33113 – Water Distribution Piping.

**E. CLARIFICATIONS**

1. Pre-Bid Meeting Minutes and Sign-In Sheets from the Pre-Bid Conference are included with the Addendum No. 1.
2. Last day for receiving Contractor questions will be COB, Wednesday, August 9, 2023.
3. Federal Wage Rates DO NOT apply to this project.
4. DBE Requirements DO apply to this project.
5. American Iron and Steel (AIS) requirements DO apply to this project.
6. B&O Taxes are NOT required for this project.
7. A Wirt County Building permit is NOT required for this project.
8. The Engineer’s cost estimate for this project is \$950,000.00.

9. Bidders are hereby notified to acknowledge the receipt of all addenda in space provided on the Bid Form.

If you have any questions or comments, please feel free to contact me at your earliest convenience. As a reminder, bids will be received until 1:00 p.m. on Thursday, August 17, 2023 at the Elizabeth Wirt Volunteer Fire Department located at 91 School View Street, Wirt County, WV. Good luck to everyone and thank you for your interest in the project.

Sincerely,

THE THRASHER GROUP, INC.

  
JESSE ALDEN, P.E.  
Project Manager

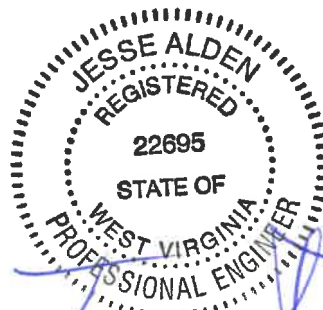

7-27-2023

**ACCOMMODATION OF UTILITIES ON  
WV DIVISION OF HIGHWAYS  
RIGHTS OF WAY JUNE 2007**

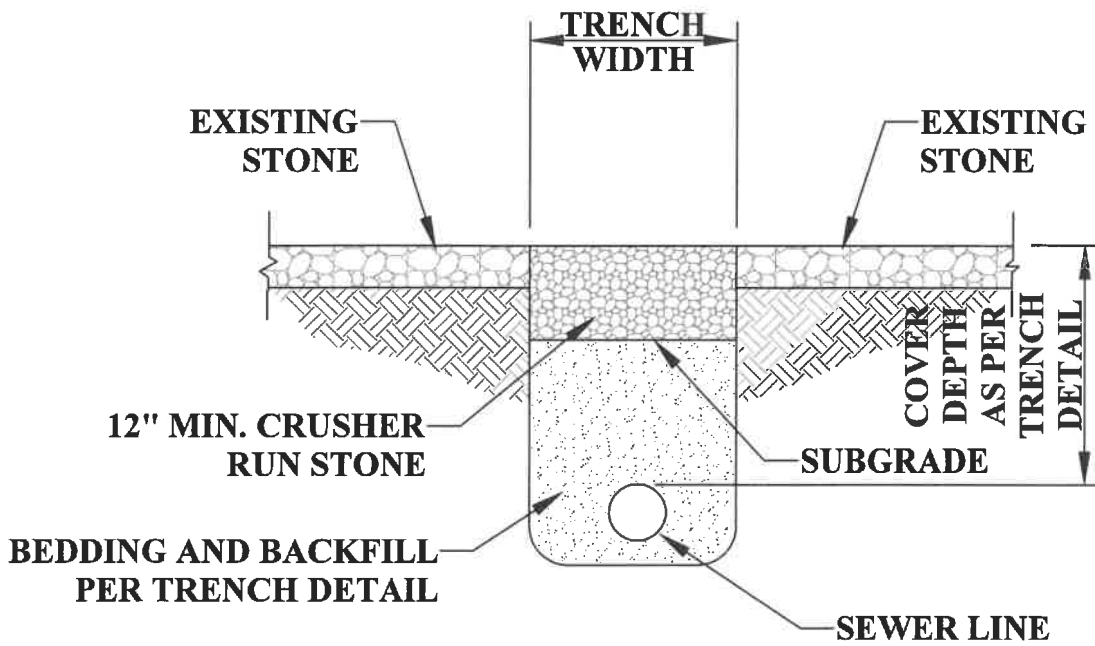

**WVDOH TYPE "C" TRENCH REPAIR**

NOT TO SCALE

TOWN OF ELIZABETH  
CONTRACT No. 1  
ADDENDUM No. 1  
TYPE "C" TRENCH REPAIR

**THRASHER**  
THE THRASHER GROUP INC.  
CIVIL • ENVIRONMENTAL • CONSULTING • FIELD SERVICES  
1000 CORPORATE LANDING, CHARLESTON, WV 25311  
PHONE (304) 343-7801 • FAX (304) 343-7804

**NOTES**  
**TOWN OF ELIZABETH**  
**75 TOWN HALL LANE**  
**ELIZABETH, WV 26143**

**CONTRACT #1 – TUCKER CREEK ROAD WATERLINE EXTENSION  
PROJECT**

**THE THRASHER GROUP, INC.**  
**1000 Corporate Landing**  
**Charleston, WV 25311**  
**Telephone # (304) 343-7601**

**PRE-BID CONFERENCE AGENDA**

**July 25, 2023**

**PROJECT LOCATION:** Wirt County, West Virginia

**ENGINEER'S PROJECT #:** 010-10193

**DATE OF CONFERENCE:** Tuesday, July 25, 2023 at 10:00 A.M., LPT

**CONFERENCE LOCATION:** Elizabeth Wirt Volunteer Fire Department  
91 School View Street  
Elizabeth, WV 26143

## **PRE-BID AGENDA**

- I. Introductions – Jesse Alden – Thrasher; **Town of Elizabeth: Bobbi Moore (Mayor), Brenda Evans, Dale Clark.**
- II. General Project Description
  - a. Contract #1 – Tucker Creek Road Waterline Extension Project - **The project consists of the following:**
    - i. **Installation of approximately 18,200 linear feet of 6” waterline, 15 new water meter pits and setters, pressure reducing valve vault and mater meter, 6 fire hydrants, and various new gate valves, and all required appurtenances.**
- III. General Bidding Information
  - a. General
    - i. **Contract #1 – Tucker Creek Road Waterline Extension Project**
      1. **Bid opening will be on August 17, 2023 per AFB**
      2. **Time - 1:00 PM per AFB**
      3. **Location: (Same Location as Pre-Bid)** Bids will be mailed or hand delivered to the Town of Elizabeth, 73 Town Hall Lane, Elizabeth, WV 26143.
    - ii. **Two Envelope System – All BOR (blue) in 1<sup>st</sup> envelope, and BID Form (Yellow) in other.**
      1. **Envelope 1**
        - a. **Name & address of Bidder**
        - b. **Bid for Contract # with name**
        - c. **Project Owner name – Town of Elizabeth**
      2. **Envelope 2**
        - a. **Placed in Envelope 1**
        - b. **Labeled “Bid Proposal”**

**iii. Contract Time**

**a. Contract #1 – Tucker Creek Road Waterline Extension Project**

- i. Substantial Completion - 90 days**
- ii. Final Completion - 120 days**
- iii. Liquidated Damages - \$1,000/day**

**b. Bid Opening Requirements - Blue Pages – Labeled BOR**

- i. Bid Submitted on Time**
- ii. Bid Bond – 5% of the total bid**
- iii. Certification of receipt of all addenda to Plans and Specifications**
- iv. WV Code §21-1D-5 Drug Free Workplace Conformance Affidavit**
- v. Disadvantaged (Small, Minority, and Women’s) Business Enterprise Certification**
- vi. WV Infrastructure and Jobs Development Council WV Jobs Act**
- vii. American Iron and Steel Requirement**
- viii. Copy of Current Contractor’s License**

**c. Bid Form - Yellow Pages – Section 410**

**1. Contract #1 – Tucker Creek Road Waterline Extension Project**

**a. 21 Unit Price Base Bid Items**

**d. Method of Award – Lowest Responsive Responsible Bidder – Base Bid.**

**IV. Details of Project**

**a. Construction Sequence of Events – As Described in the Summary Section**

**011000 for the contract.**

**b. Material and Equipment - As Described in the Plans/Specs. “Or Equal” items will be reviewed during the submittal process as described in Section 012500 “Substitution Procedures” and 013300 “Submittal Requirements”.**



c. Other Miscellaneous Items

**i. Project Estimates:**

**ii. Contract #1 – \$950,000.00**

V. Permits

a. **Bureau for Public Health Permit, NPDES Construction Stormwater Permit and WVDOH ROW Permit.**

VI. B & O Taxes/Building Permits

a. **B&O Taxes DO NOT apply to this Project. There are no Building Permits required for this project.**

VII. Office Trailer and Equipment and Storage Area

a. **Locations for the Office Trailer, Equipment and Storage Area must be coordinated with the Engineer and Owner. The area shall be included in the Pre-Construction Videos – must be set up prior to 1<sup>st</sup> pay. Will include bathroom, phone, internet, fax, etc.**

VIII. Addressing Questions

a. **Email: [jalden@thethrashergr.com](mailto:jalden@thethrashergr.com)**

**Reference Town of Elizabeth – Project Name, Please Reference Sheet # and Spec Section for all questions.**

IX. Addendum

a. **Last Day for Questions will be COB Wednesday August 9, 2023 – Addendum will be overnighted to all planholders on Friday, August 11, 2023.**

X. Funding Agencies – **This project is funded by the WVIJDC and the Wirt County Commission (ARPA). Federal Wage Rates DO NOT Apply to this contract.**

- XI. WVIJDC
- XII. MOVRC
- XIII. WVDOH
- XIV. Owner – Town of Elizabeth
- XV. Question and Answer Session

**TOWN OF ELIZABETH  
WIRT COUNTY, WEST VIRGINIA  
CONTRACT #1 – TUCKER CREEK ROAD WATERLINE EXTENSION**

**PRE-BID CONFERENCE**  
Tuesday, July 25, 2023

Thrasher Project #101-010-1040

Name	Representing	Phone #	Email Address
JESSE ALDEN	THRASHER		
Trent Shepherd	Wolfe's Excavating	304-771-7906	tshepherd@wolfesexcavating.com
BRAD MOKERS	MOURC	304-699-3709	brad.morris@Mourec.org
Brenda Evans	Town of Eliz.		
Dale Clark	Town of Eliz.		
Bernie Dunlap	Dunlap Contracting LLC	681-361-2022	dunlapcontractingllc@gmail.com
Adam Burkhammer	AJ. Burk, LLC	304-266-2479	ABurkhammer@AJBurk.com