



Department of Administration
 Purchasing Division
 2019 Washington Street East
 Post Office Box 50130
 Charleston, WV 25305-0130

**State of West Virginia
 Centralized Request for Quote**

Proc Folder: 1089036		Reason for Modification:	
Doc Description: Williamstown AASF#1 Taxiway & Apron Repairs (Construction)		Addendum No. 1 to provide pre-bid sign-in in sheets, and provide revised drawings, see attached.	
Proc Type: Central Purchase Order			
Date Issued	Solicitation Closes	Solicitation No	Version
2022-08-19	2022-09-01 13:30	CRFQ 0603 ADJ2300000007	2

BID RECEIVING LOCATION

BID CLERK
 DEPARTMENT OF ADMINISTRATION
 PURCHASING DIVISION
 2019 WASHINGTON ST E
 CHARLESTON WV 25305
 US

VENDOR

Vendor Customer Code:

Vendor Name :

Address :

Street :

City :

State : **Country :** **Zip :**

Principal Contact :

Vendor Contact Phone: **Extension:**

FOR INFORMATION CONTACT THE BUYER
 David H Pauline
 304-558-0067
 david.h.pauline@wv.gov

Vendor Signature X **FEIN#** **DATE**

All offers subject to all terms and conditions contained in this solicitation

ADDITIONAL INFORMATION

Addendum No. 1

- 1) Provide copies of the Pre-Bid Sign-in sheets for the solicitation-(see attached)
- 2) Provide revised drawings from the Architect for the solicitation- (see attached)

Bid opening remains September 1, 2022 at 1:30 pm est.

No other changes.

INVOICE TO		SHIP TO	
ADJUTANT GENERALS OFFICE 1707 COONSKIN DR		ARMY AVIATION SUPPORT FACILITY 1 387 AVIATION DR	
CHARLESTON US	WV	WILLIAMSTOWN US	WV

Line	Comm Ln Desc	Qty	Unit Issue	Unit Price	Total Price
1	Williamstown AASF#1 Taxiway & Apron Repairs (Construction)				

Comm Code	Manufacturer	Specification	Model #
72152700			

Extended Description:

BASE BID (Per documentation)- Provide and furnish all labor, materials, tools, expendable equipment and all services to complete Williamstown AASF#1 Taxiway & Apron Repairs, near Williamstown WV per the attached specifications and documentation.

INVOICE TO		SHIP TO	
ADJUTANT GENERALS OFFICE 1707 COONSKIN DR		ARMY AVIATION SUPPORT FACILITY 1 387 AVIATION DR	
CHARLESTON US	WV	WILLIAMSTOWN US	WV

Line	Comm Ln Desc	Qty	Unit Issue	Unit Price	Total Price
2	ADD-ALTERNATE 1- Per the Drawings & Specifications				

Comm Code	Manufacturer	Specification	Model #
72152700			

Extended Description:

ADD- ALTERNATE NO.1(Per documentation)- Provide and furnish all labor, materials, tools, expendable equipment and all services to complete construction per Drawings and Specifications

INVOICE TO		SHIP TO	
ADJUTANT GENERALS OFFICE 1707 COONSKIN DR		ARMY AVIATION SUPPORT FACILITY 1 387 AVIATION DR	
CHARLESTON	WV	WILLIAMSTOWN	WV
US		US	

Line	Comm Ln Desc	Qty	Unit Issue	Unit Price	Total Price
3	ADD-ALTERNATE 2- Per the Drawings & Specifications				

Comm Code	Manufacturer	Specification	Model #
72152700			

Extended Description:

ADD- ALTERNATE NO.2(Per documentation)- Provide and furnish all labor, materials, tools, expendable equipment and all services to complete construction per Drawings and Specifications

INVOICE TO		SHIP TO	
ADJUTANT GENERALS OFFICE 1707 COONSKIN DR		ARMY AVIATION SUPPORT FACILITY 1 387 AVIATION DR	
CHARLESTON	WV	WILLIAMSTOWN	WV
US		US	

Line	Comm Ln Desc	Qty	Unit Issue	Unit Price	Total Price
4	ADD-ALTERNATE 3- Per the Drawings & Specifications				

Comm Code	Manufacturer	Specification	Model #
72152700			

Extended Description:

ADD- ALTERNATE NO. 3 (Per documentation)- Provide and furnish all labor, materials, tools, expendable equipment and all services to complete construction per Drawings and Specifications

SCHEDULE OF EVENTS

Line	Event	Event Date
1	Mandatory Pre-Bid Meeting at 10:30 am est.	2022-08-17
2	Vendor Technical Questions Due By Noon est.	2022-08-26

	Document Phase	Document Description	Page
ADJ2300000007	Draft	Williamstown AASF#1 Taxiway & Apron Repairs (Construction)	4

ADDITIONAL TERMS AND CONDITIONS

See attached document(s) for additional Terms and Conditions

SOLICITATION NUMBER: CRFQ ADJ2300000007

Addendum Number: 1

The purpose of this addendum is to modify the solicitation identified as CRFQ ADJ2300000007 to reflect the change(s) identified and described below.

Applicable Addendum Category:

- Modify bid opening date and time
- Modify specifications of product or service being sought
- To respond to technical questions
- Attachment of pre-bid sign-in sheet
- Correction of error
- Other

Additional Documentation:

- 1. To attach pre-bid sign-in sheets, see attached.**
- 2. To provide revised drawing from the Architect for the solicitation, see attached.**
- 3. Bid opening date and time remains September 1, 2022, at 1:30 pm est.**
- 4. No other changes.**

Terms and Conditions:

1. All provisions of the Solicitation and other addenda not modified herein shall remain in full force and effect.
2. Vendor should acknowledge receipt of all addenda issued for this Solicitation by completing an Addendum Acknowledgment, a copy of which is included herewith. Failure to acknowledge addenda may result in bid disqualification. The addendum acknowledgement should be submitted with the bid to expedite document processing.

Pre-Bid Sign-In Sheet

Solicitation Number: ADJ2300000007
 Date of Pre-Bid Meeting: August 17th, 2022
 Location of Prebid Meeting: Williamstown, WV

Please Note:

Vendors must sign-in on this sheet to verify attendance at the Pre-Bid meeting. Failure to legibly sign in may be grounds for declaring a vendor ineligible to bid. For further verification, please also provide a business card if possible.

Firm Represented:*	Rep Name (Printed):	Firm Address:	Telephone #:	Fax #:	Email:
CFMS	Tim Stagg	Charleston, WV	304-561-6550		
CFMS	Chris Melder	Charleston, WV	304-881-2369		
WV Military Authority	Dean Wingers	1707 COMSTARS DRIVE Charleston WV 25311	304-561-1629		
Woffes excavating	Trent Shephard	70 Columbia Blvd Charleston WV 26301	304-771-7906		TShephard@woffesexcavating.com
Mid Atlantic Maintenance	Austin Edman	P.O. Box 3405 Parkersburg, WV 26103	304-483-4300		aedman@midatlanticusa.com
The Thrasher Group	Nicole Jones	600 White Oaks Blvd Bridgeport, WV 26330	304-423-5991		njones@thetrashergrp.com

*One Vendor Per Representative - No one individual is permitted to represent more than one vendor at the pre-bid meeting. Any individual that does attempt to represent two or more vendors will be required to select one vendor to which the individual's attendance will be attributed. The vendors not selected will be deemed to have not attended the pre-bid meeting unless another individual attended on their behalf.

Pre-Bid Sign-In Sheet

Solicitation Number: ADJ2300000007
 Date of Pre-Bid Meeting: August 17th, 2022
 Location of Prebid Meeting: Williamstown, WV

Please Note:

Vendors must sign-in on this sheet to verify attendance at the Pre-Bid meeting. Failure to legibly sign in may be grounds for declaring a vendor ineligible to bid. For further verification, please also provide a business card if possible.

Firm Represented:*	Rep Name (Printed):	Firm Address:	Telephone #:	Fax #:	Email:
Maintenance Snyder-Hovs	Chris Shuman	P.O. Box 686 Kingswood WV 26537	304-552-4350		Chris.Shuman@MCIWV.com
Walt Creek Contracting	Ron Patterson	488 Waterboro Rd Waterford, OH	304-538-4768		R.Patterson@walcreek contractors.com
Bear Contracting	Eric Sprouse	1 Columbia Blvd Clarksburg, WV	304-326-0160		estimating@bear-contracting.com

*One Vendor Per Representative - No one individual is permitted to represent more than one vendor at the pre-bid meeting. Any individual that does attempt to represent two or more vendors will be required to select one vendor to which the individual's attendance will be attributed. The vendors not selected will be deemed to have not attended the pre-bid meeting unless another individual attended on their behalf.

CAD FILE: R:\080\T80-11014-00-Apron Rehab-WVANG-Drawing\11014_Site_Plan.dwg
 PLOT DATE/TIME: 8/18/2022 9:46 AM
 LAYOUT: 3-OVERALL
 USER: cody winter

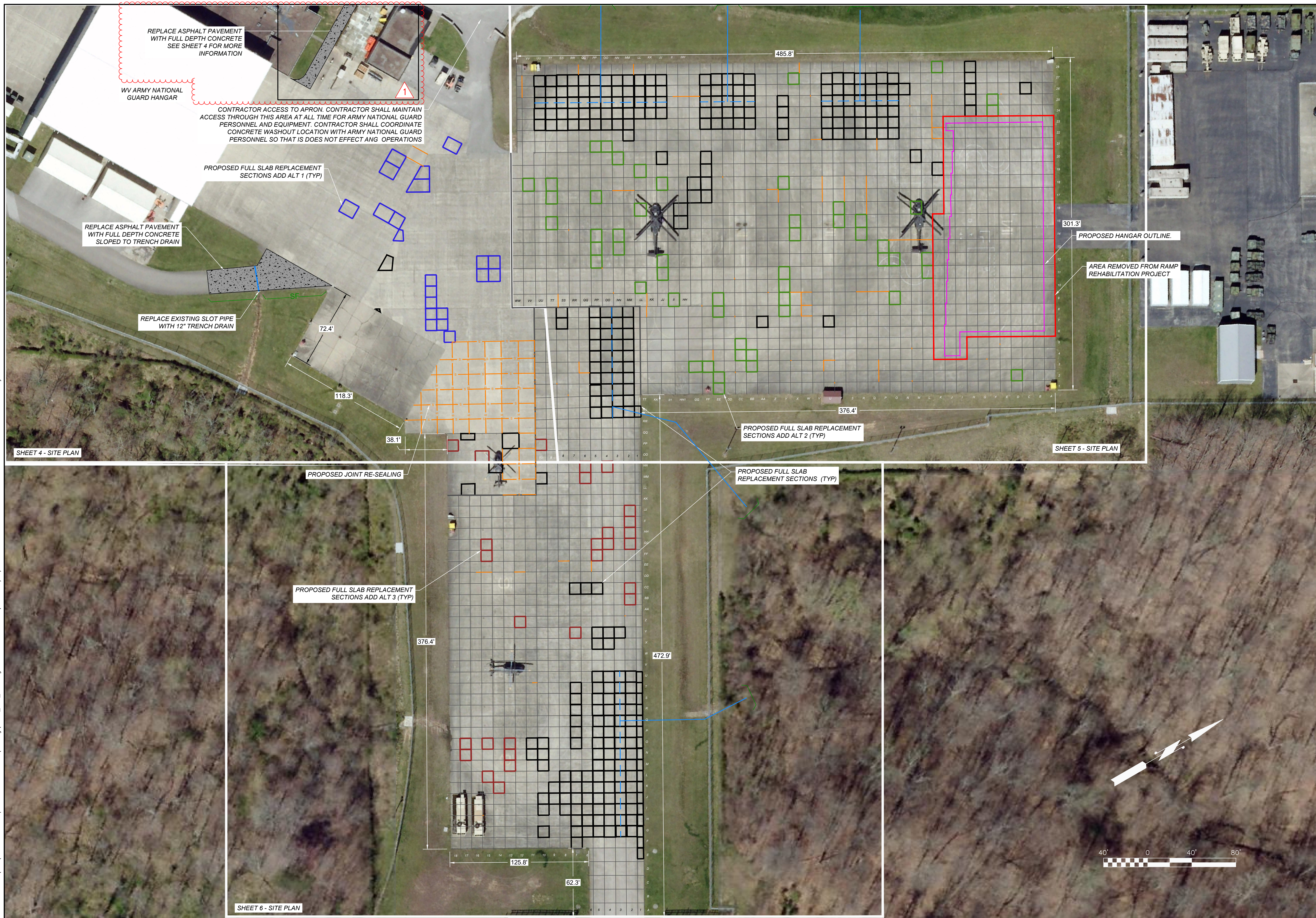

THRASHER
 THE THRASHER GROUP, INC.
 600 WHITE OAKS BLVD,
 P.O. BOX 940
 BRIDGEPORT, WV 26330
 P (304) 624-4108
 F (304) 624-7831
 www.thrashergroup.com

THE INFORMATION CONTAINED HEREIN IS THE SOLE PROPERTY OF THE THRASHER GROUP, INC. REPRODUCTION OF THESE DOCUMENTS IN WHOLE OR IN PART FOR ANY REASON WITHOUT PRIOR WRITTEN PERMISSION IS STRICTLY PROHIBITED. COPYRIGHT © 2022 THE THRASHER GROUP, INC.

NO.	BY	DATE	DESCRIPTION
1	CRW	08/16/22	REMOVED HANGAR AREA FROM PROJECT ADD'D AREA NEAR ENTRANCE

WILLIAMSTOWN AASF#1
 WEST VIRGINIA ARMY NATIONAL GUARD
 TAXIWAY AND APRON REPAIRS
 WOOD COUNTY, WEST VIRGINIA
 JUNE 22, 2022
 CONSTRUCTION PLANS

DRAWN: DATE:
 CHECKED: DATE:
 APPROVED: DATE:
 PROJECT No. T80-11014

SITE PLAN OVERALL
 SHEET No. **3**

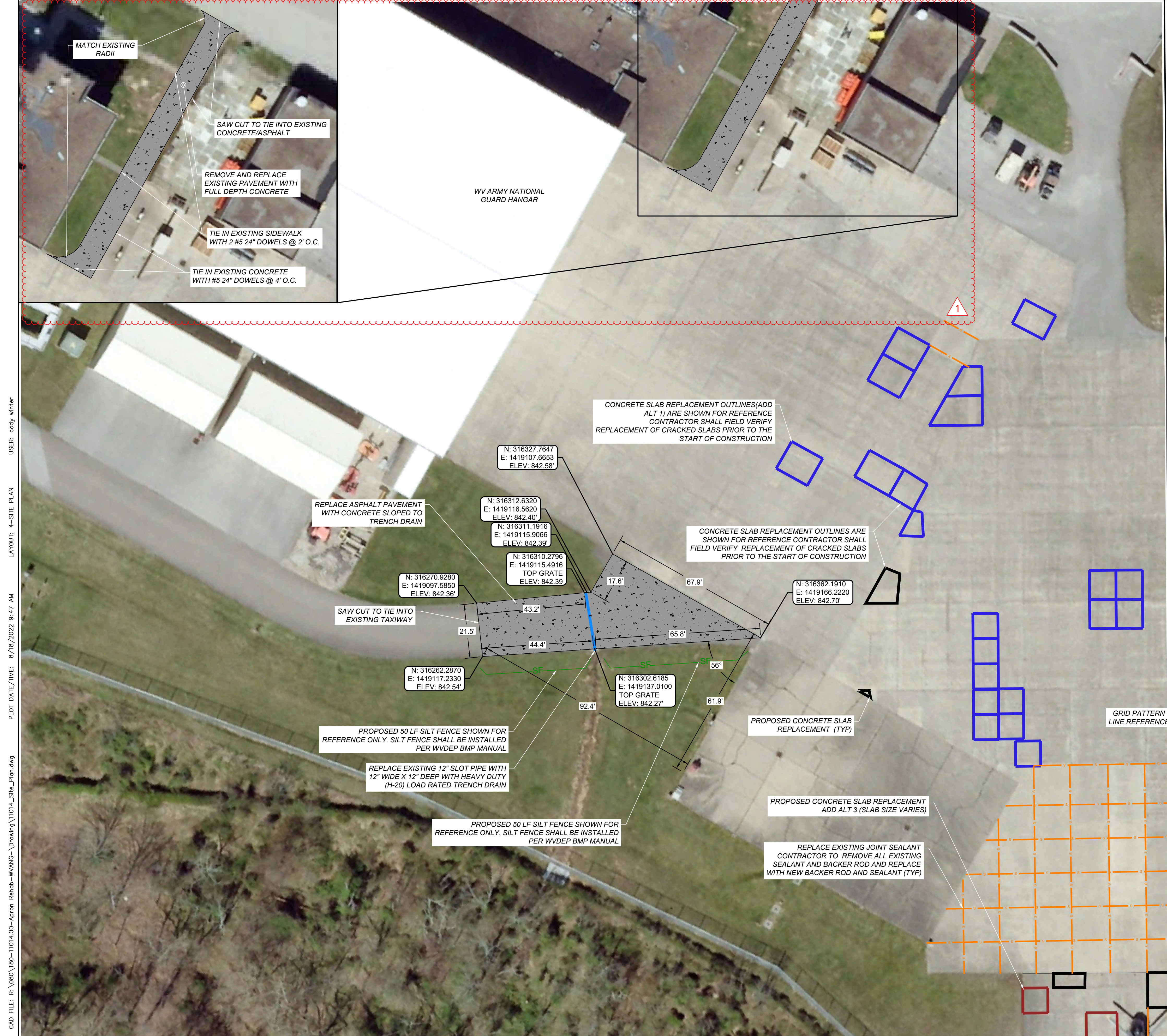

MATCHLINE SHEET 5

PLAN NOTES

1. ALL PROPOSED CONCRETE JOINTS SHALL MATCH THE EXISTING JOINT TYPE (CONSTRUCTION AND/OR EXPANSION) AND JOINT LOCATION
2. AREAS OF APRON THAT HAVE EXISTING STRIPING SHALL BE REPLACE PRIOR TO CONCRETE BEING OPENED TO TRAFFIC.
3. ALL JOINTS TO BE SEALED SHALL BE THOROUGHLY CLEANED REMOVING ALL DIRT AND LOOSE CONCRETE PRIOR TO RE-SEALING.
4. CONTROL POINT (NAIL) LOCATED AT:
 NORTHING: 317206.8880'
 EASTING: 1419277.1500'
 ELEV: 850.375'
11. CONTRACTOR IS RESPONSIBLE FOR ALL MAINTENANCE OF ACCESS TO HANGARS AS WELL AS TO AND FROM THE RUNWAY FOR THE ARMY NATIONAL GUARD. THE CONTRACTOR SHALL COORDINATE CONCRETE REPLACEMENT SCHEDULE WITH THE ARMY NATIONAL GUARD OPERATIONS SCHEDULE SO THAT ACCESS TO AND FROM THE RUNWAY IS MAINTAINED THROUGHOUT CONSTRUCTION.

THRASHER
 THE THRASHER GROUP, INC.
 600 WHITE OAKS BLVD,
 P.O. BOX 940
 BRIDGEPORT, WV 26330
 P (304) 624-4108
 F (304) 624-7831
 www.thrashergroup.com

THE INFORMATION CONTAINED HEREIN IS THE SOLE PROPERTY OF THE THRASHER GROUP, INC. REPRODUCTION OF THESE DOCUMENTS IN WHOLE OR IN PART FOR ANY REASON WITHOUT PRIOR WRITTEN PERMISSION IS STRICTLY PROHIBITED. COPYRIGHT © 2022 THE THRASHER GROUP, INC.

NO.	CRW	BY	DATE	DESCRIPTION
1			08/18/22	ADDED ADDITIONAL CONCRETE REPLACEMENT NEXT TO ENTRANCE

WILLIAMSTOWN AASF#1
TAXIWAY AND APRON REPAIRS
 WEST VIRGINIA ARMY NATIONAL GUARD
 WOOD COUNTY, WEST VIRGINIA
 JUNE 22, 2022
 CONSTRUCTION PLANS

DRAWN: DATE:
 CHECKED: DATE:
 APPROVED: DATE:
 PROJECT No. T80-11014
 PLAN SHEET
 SHEET No. 4

CAD FILE: R:\080\T80-11014-00-Apron_Repair-WWANG-Drawing\11014_Site_Plan.dwg PLOT DATE/TIME: 8/18/2022 9:47 AM LAYOUT: 4-SITE PLAN USER: cody winter

THE INFORMATION CONTAINED HEREIN IS THE SOLE PROPERTY OF THE THRASHER GROUP, INC. REPRODUCTION OF THESE DOCUMENTS IN WHOLE OR IN PART FOR ANY REASON WITHOUT PRIOR WRITTEN PERMISSION IS STRICTLY PROHIBITED. COPYRIGHT © 2022 THE THRASHER GROUP, INC.

NO.	BY	DATE	DESCRIPTION
1	CRW	08/16/22	REMOVED AREA FROM THE PROJECT DUE TO FUTURE HANGAR INSTALLATION

**WILLIAMSTOWN AASF#1
 TAXIWAY AND APRON REPAIRS**
 WEST VIRGINIA ARMY NATIONAL GUARD
 WOOD COUNTY, WEST VIRGINIA
 JUNE 22, 2022
 CONSTRUCTION PLANS

DRAWN: DATE:
 CHECKED: DATE:
 APPROVED: DATE:
 PROJECT No. T80-11014
PLAN SHEET
 SHEET No.

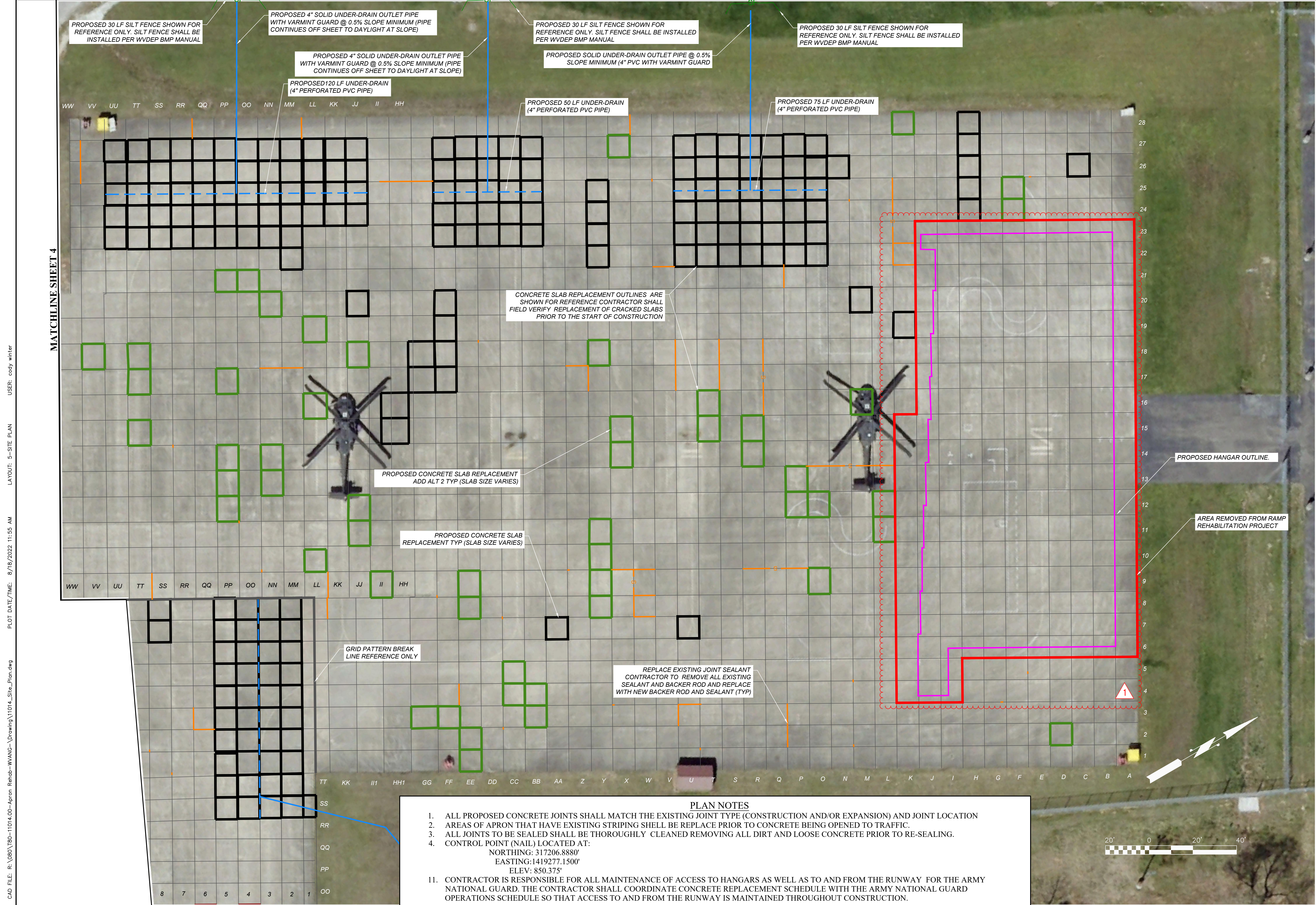

CAD FILE: R:\080\T80-11014-00-Apron_Repair-WVANG-Drawing\11014_Site_Plan.dwg
 PLOT DATE/TIME: 8/18/2022 11:55 AM
 LAYOUT: 5-SITE PLAN
 USER: cody whitler

PLAN NOTES

- ALL PROPOSED CONCRETE JOINTS SHALL MATCH THE EXISTING JOINT TYPE (CONSTRUCTION AND/OR EXPANSION) AND JOINT LOCATION
- AREAS OF APRON THAT HAVE EXISTING STRIPING SHELL BE REPLACE PRIOR TO CONCRETE BEING OPENED TO TRAFFIC.
- ALL JOINTS TO BE SEALED SHALL BE THOROUGHLY CLEANED REMOVING ALL DIRT AND LOOSE CONCRETE PRIOR TO RE-SEALING.
- CONTROL POINT (NAIL) LOCATED AT:
 NORTHING: 317206.8880'
 EASTING: 1419277.1500'
 ELEV: 850.375'
- CONTRACTOR IS RESPONSIBLE FOR ALL MAINTENANCE OF ACCESS TO HANGARS AS WELL AS TO AND FROM THE RUNWAY FOR THE ARMY NATIONAL GUARD. THE CONTRACTOR SHALL COORDINATE CONCRETE REPLACEMENT SCHEDULE WITH THE ARMY NATIONAL GUARD OPERATIONS SCHEDULE SO THAT ACCESS TO AND FROM THE RUNWAY IS MAINTAINED THROUGHOUT CONSTRUCTION.

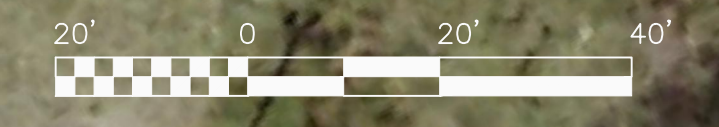

THE INFORMATION CONTAINED HEREIN IS THE SOLE PROPERTY OF THE THRASHER GROUP, INC. REPRODUCTION OF THESE DOCUMENTS IN WHOLE OR IN PART FOR ANY REASON WITHOUT PRIOR WRITTEN PERMISSION IS STRICTLY PROHIBITED. COPYRIGHT © 2022 THE THRASHER GROUP, INC.

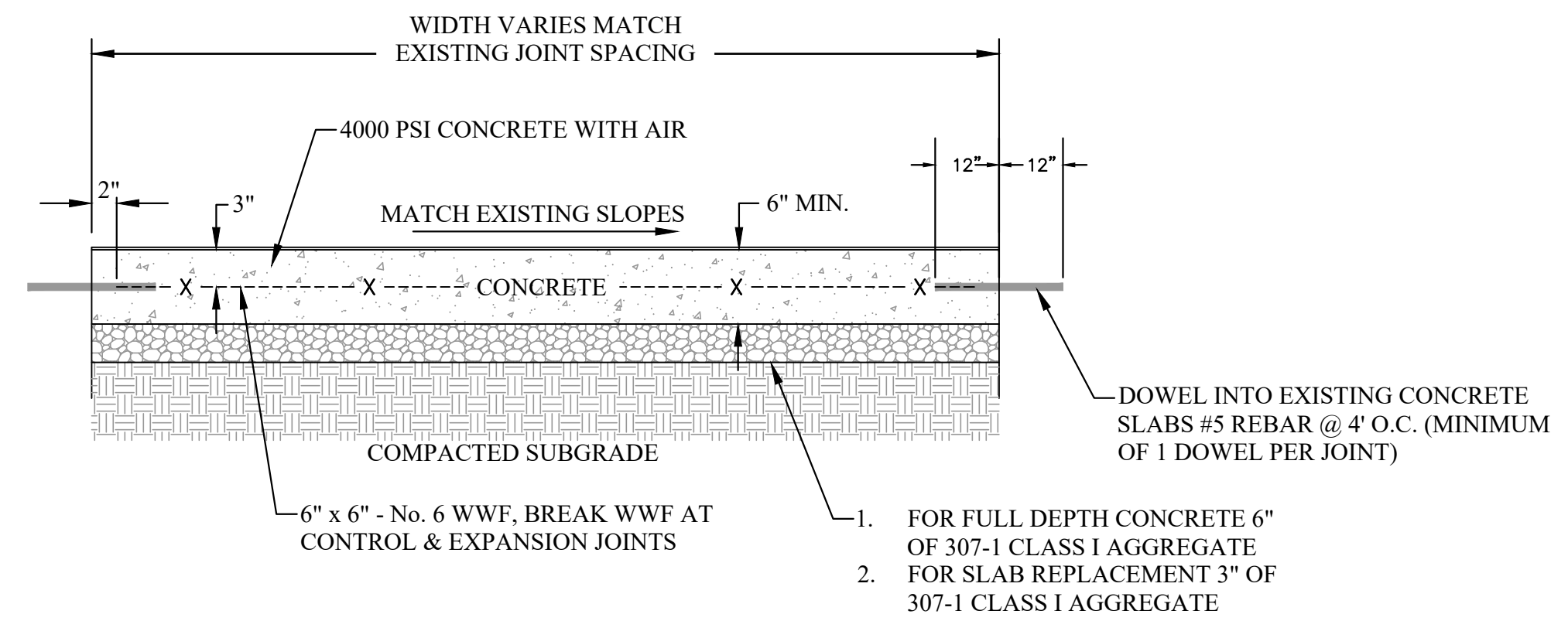

- NOTES:**
1. PLACE EXPANSION JOINT ALONG EXISTING CONCRETE SLABS AND STRUCTURES.
 2. PLACE EXPANSION JOINTS TO MATCH EXISTING EXPANSION JOINT LOCATIONS.
 3. PLACE CONTRACTION JOINTS TO MATCH EXISTING CONTRACTION JOINT LOCATIONS
 4. FINISH SURFACE WITH A NON-SLIP BROOM SWEEP FINISH.

TYPICAL CONCRETE REPLACEMENT SECTION
 NOT TO SCALE

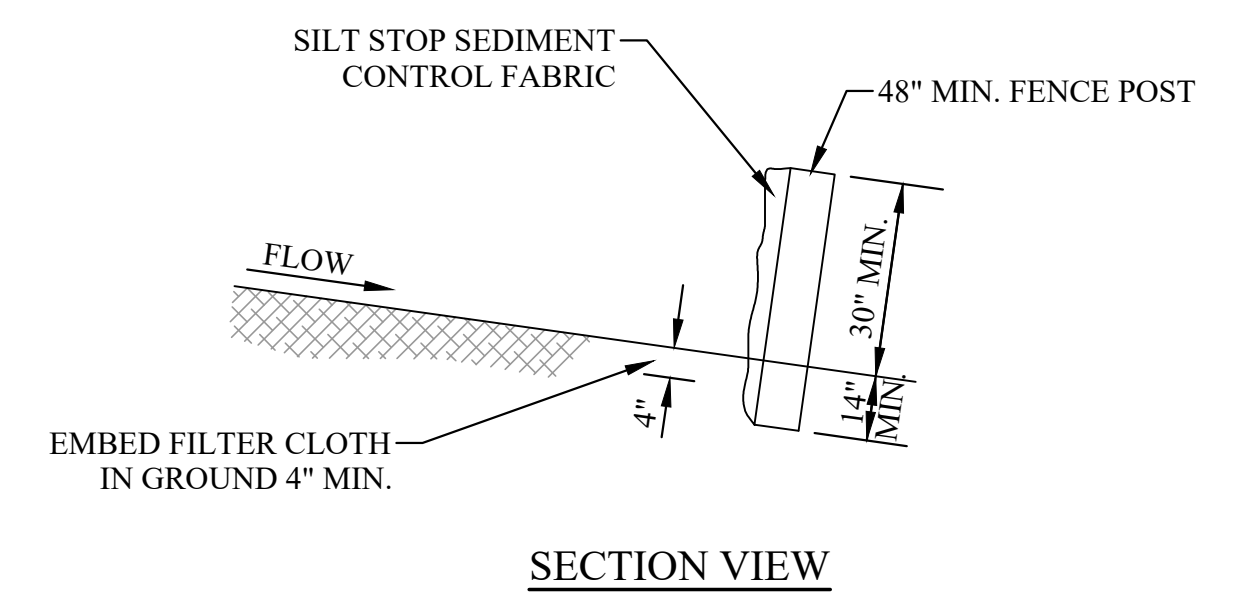

- NOTE:**
1. SET SILT FENCE PARALLEL TO THE CONTOURS AT ALL POINTS ALONG ITS LENGTH

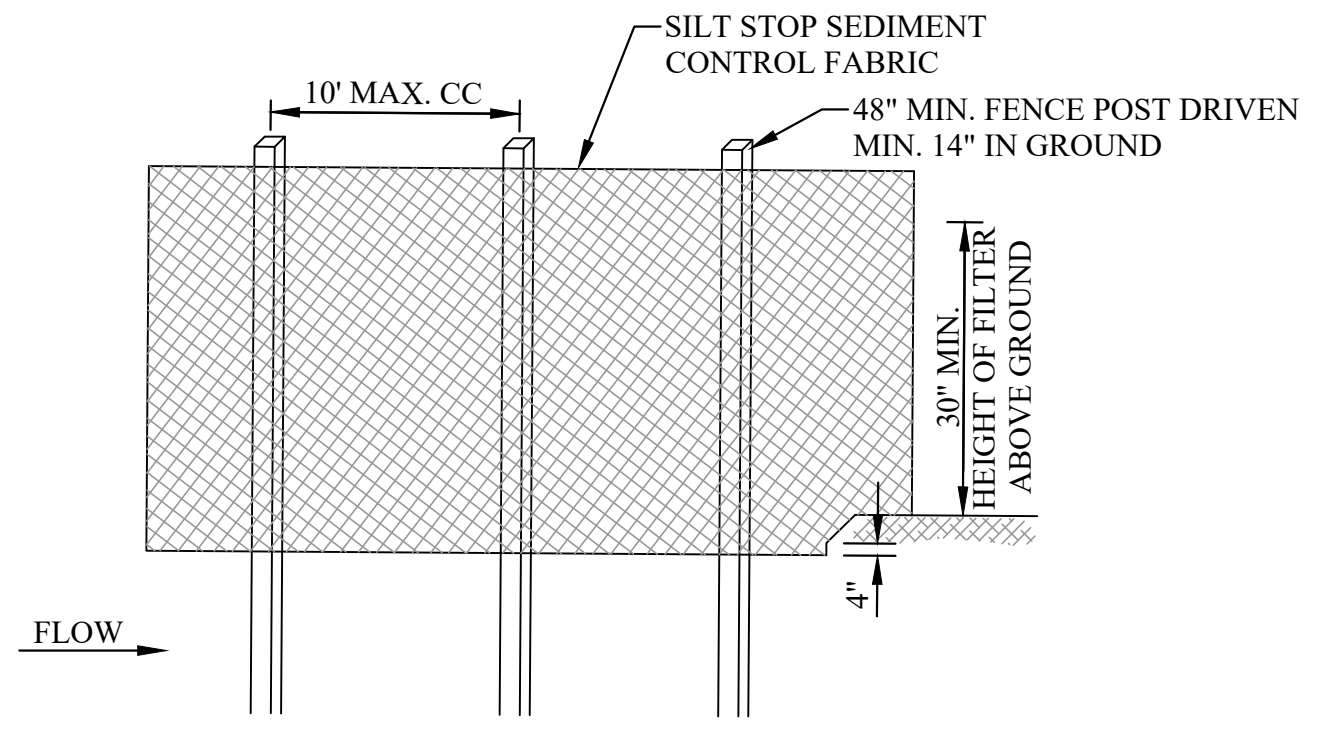

SILT FENCE
 NOT TO SCALE

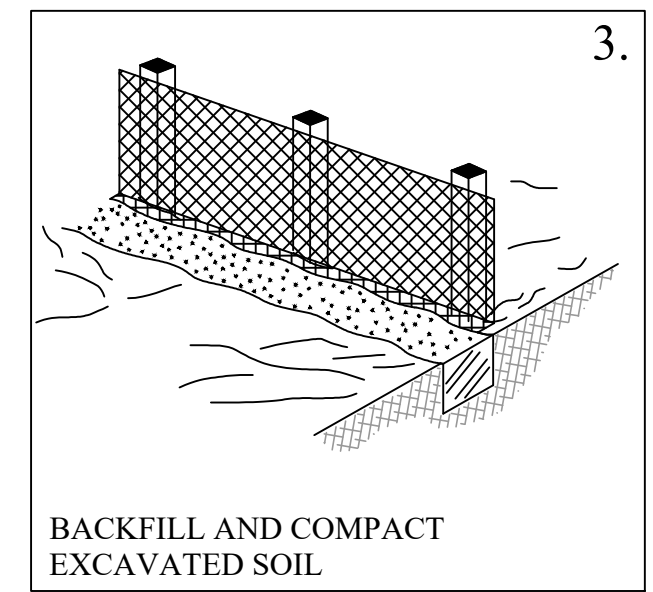
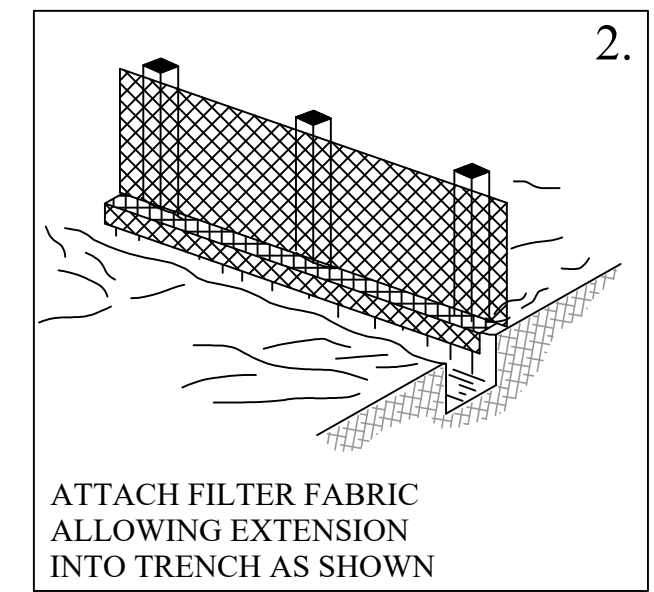
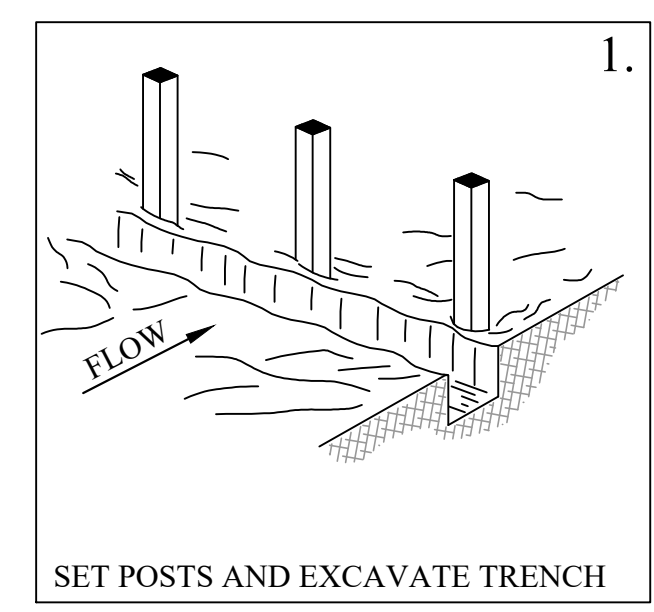

BUILDING SILT FENCE - STEP BY STEP PROCEDURE
 NOT TO SCALE

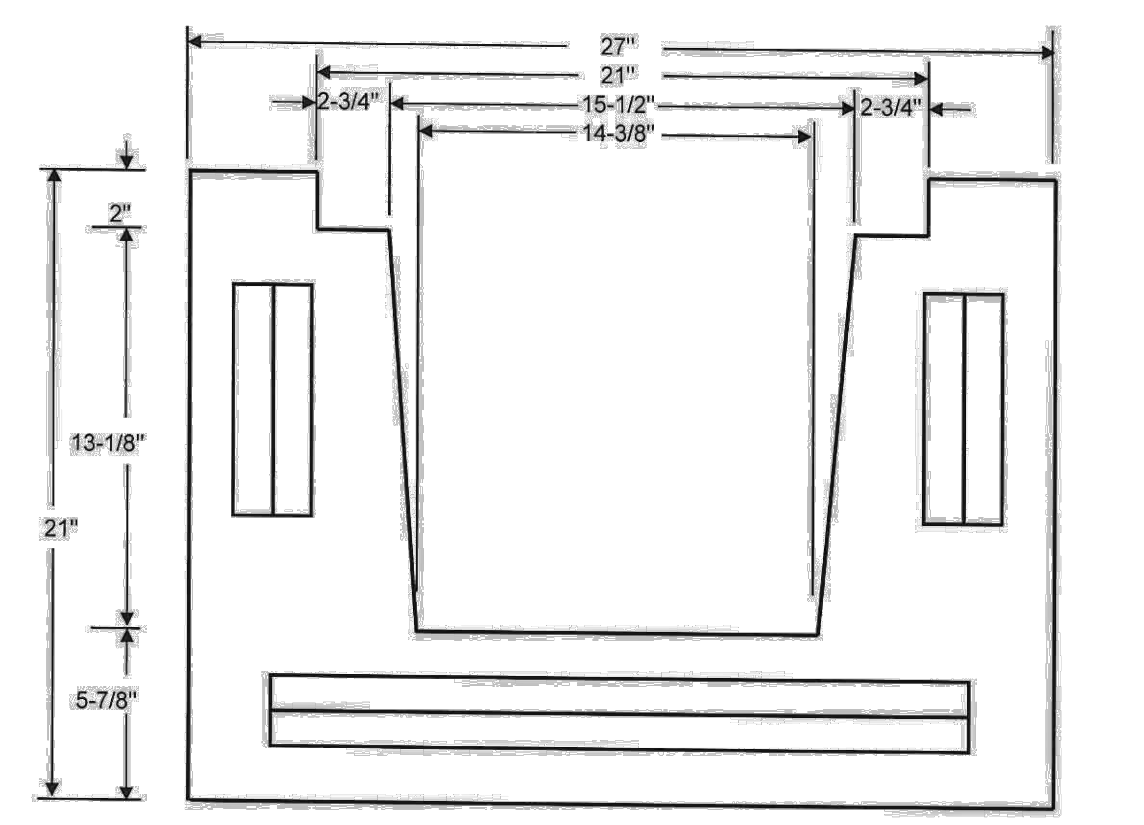

SECTION

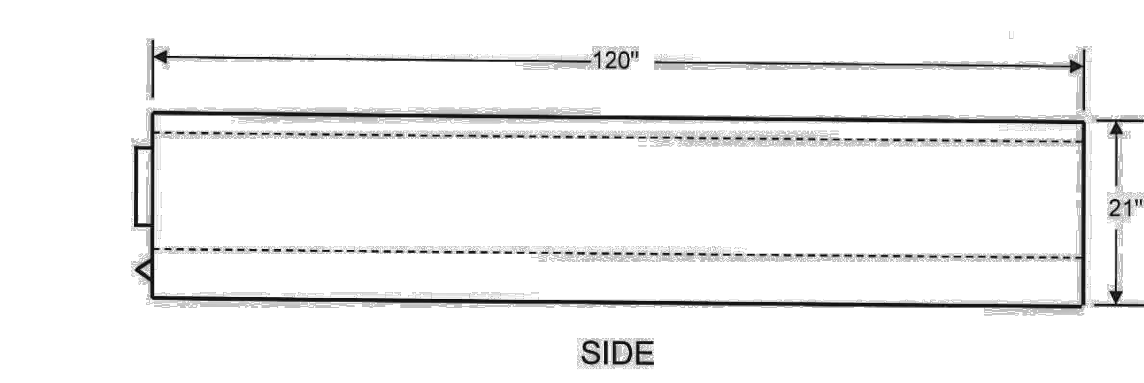

SIDE

TRENCH DRAIN DETAIL
 NOT TO SCALE

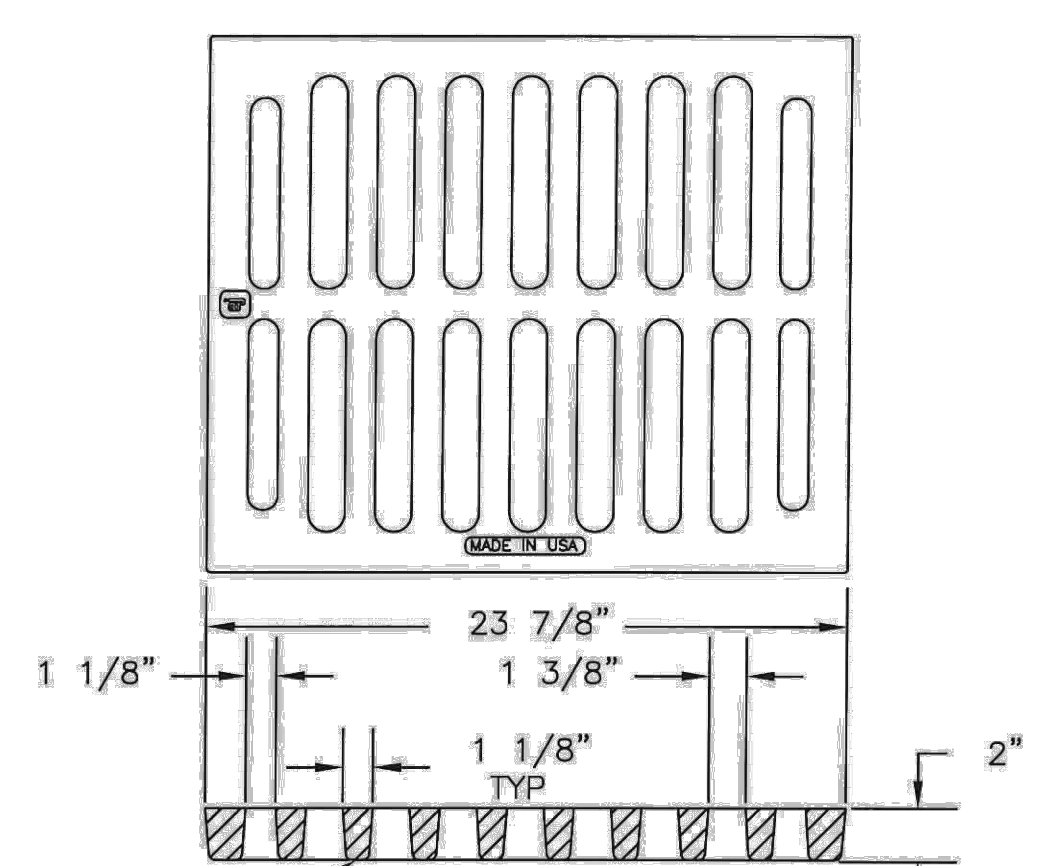

SECTION

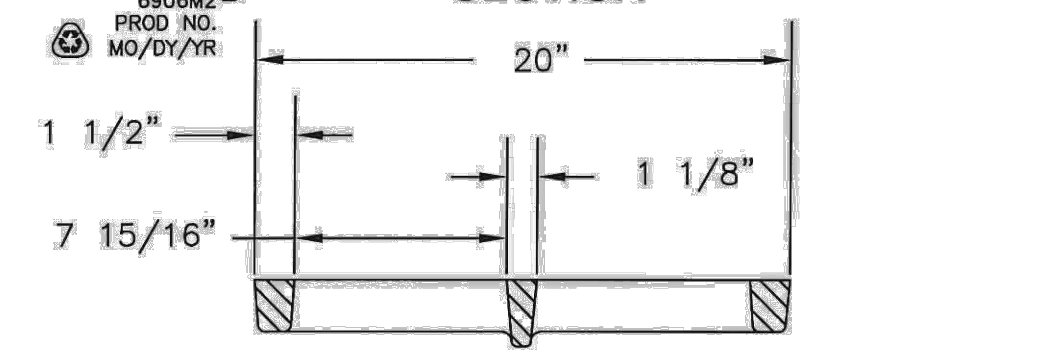

SECTION

TRENCH GRATE DETAIL
 NOT TO SCALE

- NOTES:**
1. THE CONTRACTOR SHALL FURNISH, INSTALL, SECURE AND MAINTAIN THE BARRICADES FOR THE DURATION OF THE PROJECTS COMPLETION.
 2. THE CONTRACTOR SHALL ENSURE THE LIGHTS, BATTERY, AND PHOTOCELL ARE IN WORKING ORDER PRIOR TO LEAVING THE SITE EVERY NIGHT. CONTRACTOR SHALL ENSURE THAT BARRICADES CONFORM TO THE LATEST ADVISORY CIRCULAR AND ARE FILLED WITH WATER OR SAND PRIOR TO MOVEMENT.
 3. BARRICADES SHALL BE LOCATED AS DEFINED IN THE CONSTRUCTION SAFETY AND PHASING PLAN (CSPP) WITH A MAXIMUM SPACING OF 16' O.C. OR AS DIRECTED BY THE ENGINEER.
 4. CONTRACTOR SHALL REPLACE ANY DAMAGED LOW PROFILE BARRICADES AT NO ADDITIONAL COST TO THE OWNER.
 5. LIGHTS MUST BE RED, EITHER BY STEADY BURNING OR FLASHING, AND MUST MEET THE LUMINANCE REQUIREMENT OF THE DIVISION OF HIGHWAYS. LIGHTS MUST BE MOUNTED ON BARRICADES AND SPACED AT NO MORE THAN 10 FT. LIGHTS MUST BE OPERATED BETWEEN SUNSET AND SUNRISE AND DURING PERIODS OF LOW-VISIBILITY WHENEVER THE AIRPORT IS OPEN TO OPERATIONS. THE LIGHTS MAY BE BATTERY POWERED OR OPERATED BY PHOTOCELL. THE CONTRACTOR MAY BE REQUIRED TO RUN THEM ON MANUALLY DURING LOW-VISIBILITY SITUATIONS.

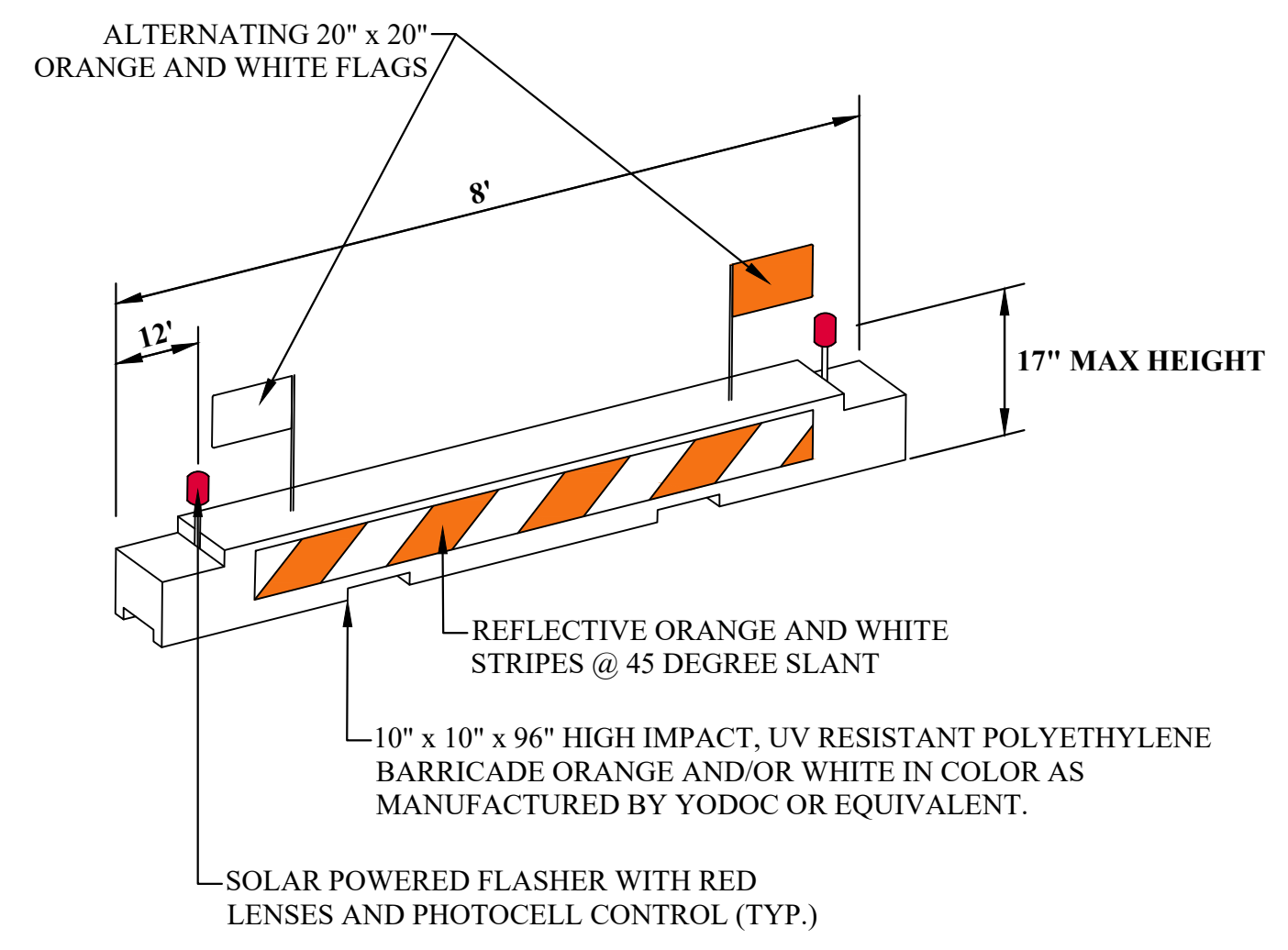

LOW PROFILE AIRCRAFT BARRICADES
 NOT TO SCALE

NO.	BY	DATE	DESCRIPTION
1	CRW	UPDATED	CONCRETE REPLACE DETAIL STONE DEPTHS

WILLIAMSTOWN AASF#1
TAXIWAY AND APRON REPAIRS
 WEST VIRGINIA ARMY NATIONAL GUARD
 WOOD COUNTY, WEST VIRGINIA
 JUNE 22, 2022
 CONSTRUCTION PLANS

DRAWN: DATE:
 CHECKED: DATE:
 APPROVED: DATE:
 PROJECT No. T80-11014

DETAILS

SHEET No. **7**

ADDENDUM ACKNOWLEDGEMENT FORM
SOLICITATION NO.: CRFQ ADJ2300000007

Instructions: Please acknowledge receipt of all addenda issued with this solicitation by completing this addendum acknowledgment form. Check the box next to each addendum received and sign below. Failure to acknowledge addenda may result in bid disqualification.

Acknowledgment: I hereby acknowledge receipt of the following addenda and have made the necessary revisions to my proposal, plans and/or specification, etc.

Addendum Numbers Received:

(Check the box next to each addendum received)

- | | | | |
|-------------------------------------|----------------|--------------------------|-----------------|
| <input checked="" type="checkbox"/> | Addendum No. 1 | <input type="checkbox"/> | Addendum No. 6 |
| <input type="checkbox"/> | Addendum No. 2 | <input type="checkbox"/> | Addendum No. 7 |
| <input type="checkbox"/> | Addendum No. 3 | <input type="checkbox"/> | Addendum No. 8 |
| <input type="checkbox"/> | Addendum No. 4 | <input type="checkbox"/> | Addendum No. 9 |
| <input type="checkbox"/> | Addendum No. 5 | <input type="checkbox"/> | Addendum No. 10 |

I understand that failure to confirm the receipt of addenda may be cause for rejection of this bid. I further understand that that any verbal representation made or assumed to be made during any oral discussion held between Vendor's representatives and any state personnel is not binding. Only the information issued in writing and added to the specifications by an official addendum is binding.

Company

Authorized Signature

Date

NOTE: This addendum acknowledgement should be submitted with the bid to expedite document processing.