



Purchasing Division
 2019 Washington Street East
 Post Office Box 50130
 Charleston, WV 25305-0130

State of West Virginia
 Request for Quotation
 09 - Construction

Proc Folder: 677503

Doc Description: Addendum 2 - Construction of Boat access on Lower Elk River

Proc Type: Central Purchase Order

Date Issued	Solicitation Closes	Solicitation No	Version
2020-02-14	2020-02-27 13:30:00	CRFQ 0310 DNR2000000007	3

BID RECEIVING LOCATION

BID CLERK
 DEPARTMENT OF ADMINISTRATION
 PURCHASING DIVISION
 2019 WASHINGTON ST E
 CHARLESTON WV 25305
 US

VENDOR

Vendor Name, Address and Telephone Number:

FOR INFORMATION CONTACT THE BUYER

Guy Nisbet
 (304) 558-2596
 guy.l.nisbet@wv.gov

Signature X FEIN # DATE

All offers subject to all terms and conditions contained in this solicitation

ADDITIONAL INFORMATION:

Addendum

Addendum No.02 issued to publish and distribute the attached information to the vendor community.

**Request for Quotation
(Construction Services - Kanawha County, Lower Elk River (5) Boating Access Site Project)**

In accordance with WV Code 5A-3 and WV Code 5-22, The West Virginia Purchasing Division is soliciting bids on behalf of the Agency The WV. Division of Natural Resources (WV DNR) to establish a one-time construction contract for five (5) Boating Access sites located on the lower Elk River in Kanawha County, West Virginia (Big Chimney, Blue Creek, Clendenin-North, Coonskin, and Clendenin-South) per the specifications, terms and conditions that are a part of this solicitation and reference herein.

INVOICE TO		SHIP TO	
DIVISION OF NATURAL RESOURCES PARKS & RECREATION-PEM SECTION 324 4TH AVE SOUTH CHARLESTON WV25305 US		STATE OF WEST VIRGINIA JOBSITE - SEE SPECIFICATIONS No City WV 99999 US	

Line	Comm Ln Desc	Qty	Unit Issue	Unit Price	Total Price
1	Marine construction services	0.00000			

Comm Code	Manufacturer	Specification	Model #
72141200			

Extended Description :
Construction of five (5) new boat access ramps along the Lower Elk River.

SOLICITATION NUMBER: CRFQ 0313 DNR2000000007

Addendum Number:

No.02

The purpose of this addendum is to modify the solicitation identified as (“Solicitation”) to reflect the change(s) identified and described below.

Applicable Addendum Category:

- | Modify bid opening date and time
- | Modify specifications of product or service being sought
- | Attachment of vendor questions and responses
- | Attachment of pre-bid sign-in sheet
- | Correction of error
- | Other

Description of Modification to Solicitation:

Addendum issued to publish and distribute the attached documentation to the vendor community.

1. Bid Opening was scheduled for: 02/20/2020 at 1:30 PM. ET.
now scheduled for: 02/27/2020 at 1:30 PM. ET.
2. Revised Exhibit A Pricing Page dated: 02/14/2020
3. Pre-Bid Meeting notes
4. Vendor Submitted Question and Agency Response
5. PDF Drawings Sheets No. 4,15,16, 10, and 13 (6 pages) PDF version upload to VSS for vendors ability to view and print.

Additional Documentation: Documentation related to this Addendum (if any) has been included herewith as Attachment A and is specifically incorporated herein by reference.

Terms and Conditions:

1. All provisions of the Solicitation and other addenda not modified herein shall remain in full force and effect.
2. Vendor should acknowledge receipt of all addenda issued for this Solicitation by completing an Addendum Acknowledgment, a copy of which is included herewith. Failure to acknowledge addenda may result in bid disqualification. The addendum acknowledgement should be submitted with the bid to expedite document processing.

ATTACHMENT A

EXHIBIT A
REVISED PRICING PAGE (02/14/2020)
Elk River Boat Ramps Project

Name of Vendor:

Address of Vendor:

Phone Number of Vendor

We, the undersigned, having examined the site and being familiar with the local conditions affecting the cost of the work and also being familiar with the general conditions to vendors, drawings, and specifications, hereby proposes to furnish all materials, equipment, and labor to complete all work in a workmanlike manner, as described in the Bidding documents.

Base Bid

The Base Bid shall consist of construction of the facility and related work described in the drawings and specifications; **Total Base Bid** shall be indicated in the space below.

Total Base Bid:
Lump sum for all labor, materials, and equipment as stipulated in the Bidding Documents, written in figures.

Total Base Bid: Lump sum for all labor, materials, and equipment as stipulated in the Bidding Documents, written in words.

EXHIBIT A

REVISED PRICING PAGE (02/14/2020)
Elk River Boat Ramps Project

**Add Alternate No. 1:
Boulders - Unit Price**
per boulder for all
labor, materials, and
equipment as stipulated
in the
Bidding Documents,
written in figures.

--

**Add Alternate No. 1:
Boulders - Unit Price**
per boulder for all
labor, materials, and
equipment as stipulated
in the
Bidding Documents,
written in words.

--

**Unclassified Borrow
Material: Unit Price**
per cubic yard for all
labor, materials, and
equipment as stipulated
in the
Bidding Documents,
written in figures.

--

**Unclassified Borrow
Material: Unit Price**
per cubic yard for all
labor, materials, and
equipment as stipulated
in the
Bidding Documents,
written in words.

--

Unit prices for Unclassified Borrow material is for the replacement of potential unsuitable material and are for use in negotiations should a change order be necessary

**WV DNR
KANAWHA COUNTY, WEST VIRGINIA
PROPOSED
ELK RIVER BOATING ACCESS SITES**

**ADDENDUM #2
February 14, 2020**

The following are clarifications and responses to questions posed by contractors for the above reference project. This Addendum forms a part of the Contract Documents and modifies the original Bidding Documents dated January 2020.

CLARIFICATIONS:

1. The Bid Opening for the WV DNR Elk River Boating Access Sites Project **HAS BEEN RESCHEDULED FOR THURSDAY, FEBRUARY 27, 2020 AT 1:30 P.M., L.P.T.**
2. Bid Form has been revised to include additive Alternate #1 and add a unit price for fill unclassified borrow material in the event there are unsuitable materials. Contractor to use Revised Exhibit A Price Pages (02/14/2020) in submitting bid, See pages 36-1, and 36-2, within this Addendum.

PRE-BID MEETING CLARIFICATIONS:

- Q1.) What is the D50 sizing on the slope protection.
- A1.) The slope protection on the Big Chimney Boat Ramp shall have a minimum diameter of 8 inches. See revised drawing 4 for Big Chimney.
- Q2.) Will the Guardrail on Blue Creek be removed by WVDOH or Contractor?
- A2.) The contractor shall coordinate with the WVDOH about guardrail removal.

Q3.) Do we know the sewer flow to properly size the pump for a pump around?

A3.) The current flow is not known, the contractor shall coordinate with the owner of the sanitary sewer for flow and bypass information, and or temporary shut down of the existing pump station.

Q4.) Is there a maintenance of traffic requirement?

A4.) Temporary traffic control shall be in accordance with section 636 of the West Virginia Department of Transportation Division of Highways, Standard Specifications, Roads and Bridges. Adopted 2017, and the West Virginia Department of Transportation, Division of Highways, Supplemental Specifications Dated January 1, 2019, and the Manual on Temporary Traffic control for Streets, and Highways 2006.

Q5.) Is there a Geotech Report available for the site?

A5.) A Geotech Report is available for review at the “The Thrasher Group’s” office located at 160 Association Drive, Charleston WV 25313. Contact Brenda Ashley or Shawn Kelly at 304-343-7601 to schedule an appointment.

Q6.) Is a turbidity curtain required or can a coffer dam be used?

6A.) The contractor may use either a Turbidity Curtain or Cofferdam.

7Q.) Kiosk location and detail clarification.

7A.) See revised detail sheets:

Coonskin – Sheet 10

Big Chimney – Sheet 15

Blue Creek – Sheet 16

Clendenin South – Sheet 13

Clendenin North – Sheet 10

8Q.) What type of payment or how will the Contractor be paid?

8A.) Payment information was provided in the CRFQ documents.

9Q.) The plans indicate an additive alternate #1 for Boulders, however there is no add alternate on the Bid Form?

9A.) Bid Form has been revised via this addendum.

10Q.) In the event there are unsuitable materials on-site and there is not enough material between the sites to complete the earthwork, how will this be addressed.

10A.) Contractors will be able to provide a unit price for unclassified borrow material pending un-suitable material for fill on the revised Bid Form. This unit price will be used to negotiate a change order in the event that unsuitable material is found

As a reminder, bids will be received until 1:30 p.m. on Thursday, February 27, 2020 at Department of Administration, Purchasing Division, 2019 Washington Street East, Charleston, WV 25305.

Robert R. Milne, PE
Sr. Project Manager

CRFQ DNR 0310 DNR2000000007**Kanawha County Lower Elk River Five (5) Boat Access Ramps Project
Vendor submitted Questions and Agency Responses
February 10th, 2020 at 9:00 AM. ET.**

1. Within the Elk River Boat Ramp improvement project bid, do any of the sites have new Floating courtesy docks designed into their bid features.

A. NO.

- PLAN LEGEND**
- EXISTING CONTOUR
 - EXISTING PROPERTY LINE
 - EXISTING CENTERLINE
 - EXISTING ASPHALT
 - EXISTING CONCRETE
 - EXISTING CHAUNDRALL
 - EXISTING EDGE OF RIVERBANK / SLUICE
 - EXISTING RIVER DOOR
 - EXISTING CHAUNDRALL TOTALITY
 - EXISTING UNDERGROUND GAS
 - EXISTING FURST MARKER
 - EXISTING WATER VALVE
 - EXISTING FIRE HYDRANT
 - PROPOSED CURBLINE
 - PROPOSED EDGE OF PAVEMENT
 - PROPOSED ASPHALT
 - PROPOSED CONCRETE
 - PROPOSED PAVEMENT MARKING
 - PROPOSED CHAUNDRALL
 - PROPOSED FENCE
 - PROPOSED GRAVEL
 - PROPOSED ASPHALT DRIVE
 - PROPOSED ASPHALT DRIVE IMPERMEABLE
 - PROPOSED ASPHALT DRIVE PERMEABLE
 - PROPOSED DRIVE

PLAN NOTES

- CONTOUR INTERVAL IS 1 FT.
- PROPOSED BOLLARDS ARE TO BE APPROXIMATELY 7' WIDE AND 4' HIGH. THE BOLLARDS ARE TO BE PLACED NO MORE THAN 1' APART.

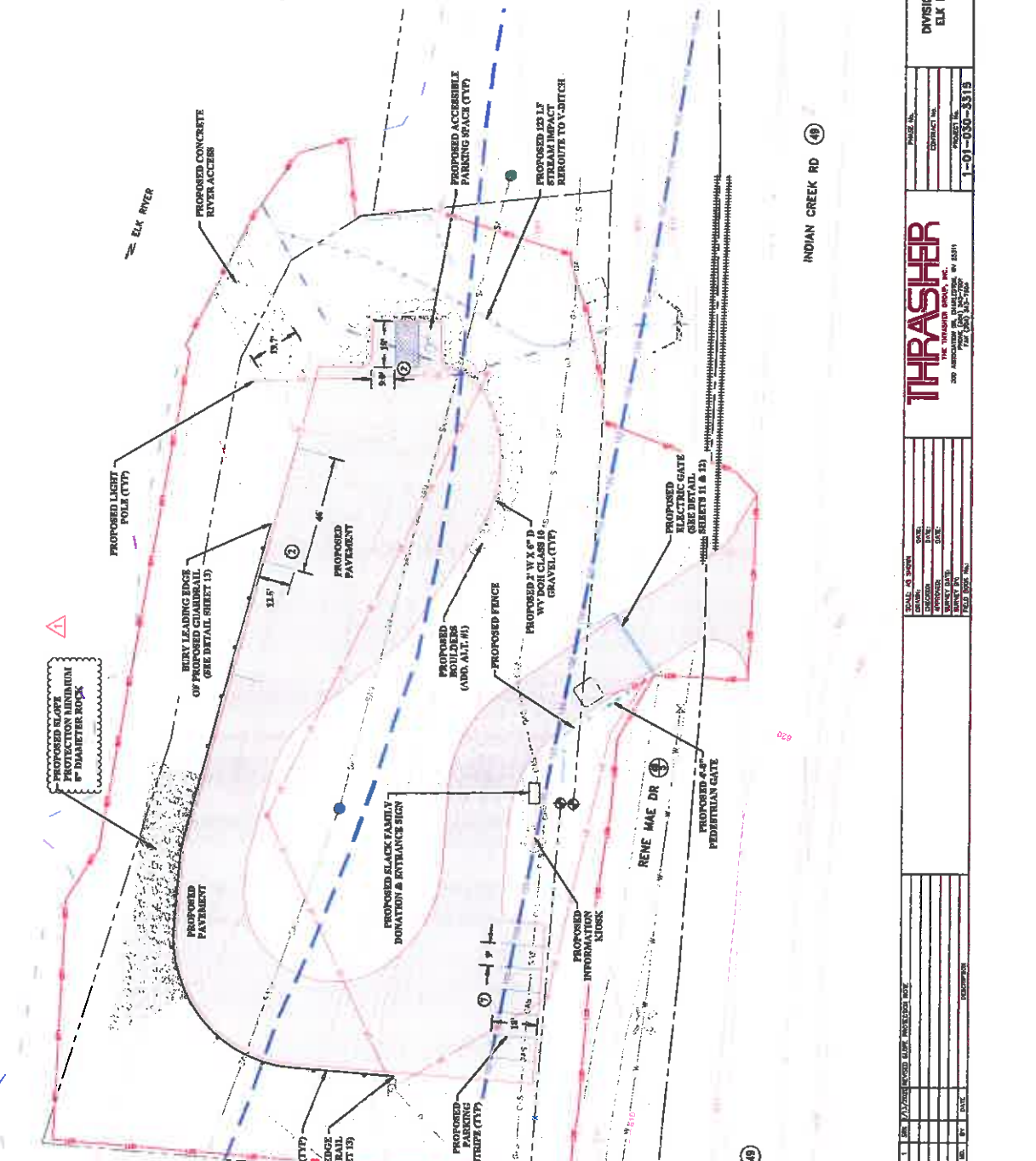
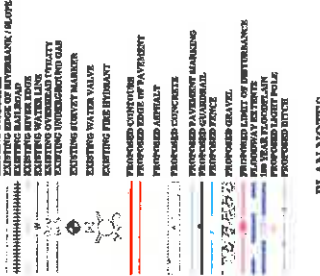

THRASHER 300 HARRISON AVENUE, SUITE 301 WASHINGTON, DC 20005 TEL: (202) 238-7878 FAX: (202) 238-7879		SHEET NO. 4
WEST VIRGINIA DIVISION OF NATURAL RESOURCES ELK RIVER HEATING ACCESS SITES OVERALL SITE PLAN		PROJECT NO. 1-01-050-3375
SCALE AS SHOWN DATE: _____ DRAWN BY: _____ CHECKED BY: _____ APPROVED: _____ DESIGN DATE: _____ DESIGN NO.: _____ FIELD BOOK NO.: _____	PHASE NO. CONTRACT NO. PROJECT NO. 1-01-050-3375	SHEET NO. 4

THE INFORMATION CONTAINED HEREIN IS THE SOLE PROPERTY OF THIRASHER ENGINEERING. NO REPRODUCTION OR TRANSMISSION IS ALLOWED WITHOUT WRITTEN PERMISSION FROM THIRASHER ENGINEERING, INC.

LABEL	QUANTITY	MANUFACTURER	CATALOG NUMBER	DESCRIPTION	LAMP	NUMBER LAMPS	FILENAME	LUMENS PER LAMP	LIGHT LOSS FACTOR	WATTAGE
A	5	GREENSHINE NEW ENERGY	GS-LED-NR-16-T3-40W-40K-BK	16 LED TYPE III OPTICS, 700MA 4000K STREET LIGHT FIXTURE	16 4000K LED	1	GS-LED-NR-16-T3-40W-40K-BK	4100	1	40
B	0	GREENSHINE NEW ENERGY	GS-LED-NR-16-T3-40W-40K-BK	16 LED TYPE III OPTICS, 700MA 400K STREET LIGHT FIXTURE	16 4000K LED	0	GS-LED-NR-16-T3-40W-40K-BK V17.1B	4100	1	40
C	0	GREENSHINE NEW ENERGY	GS-LED-NR-16-T3-40W-40K-BK	16 LED TYPE V OPTICS, 700MA 400K STREET LIGHT FIXTURE	16 4000K LED	0	GS-LED-NR-16-T3-40W-40K-BK V17.1B	4100	1	40

LIGHTING FIXTURE SCHEDULE

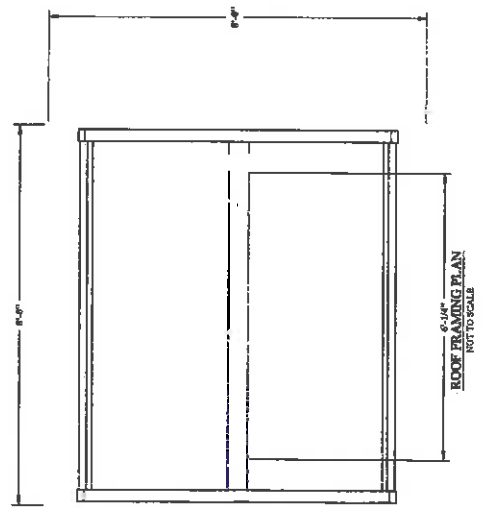
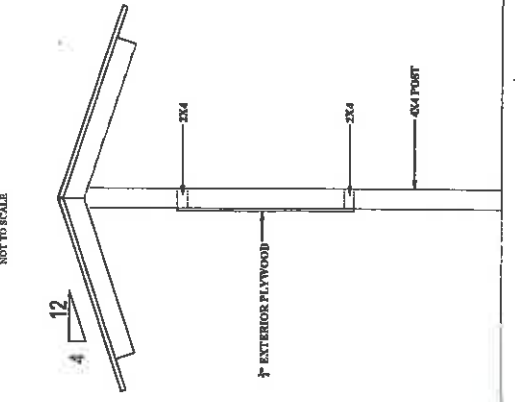
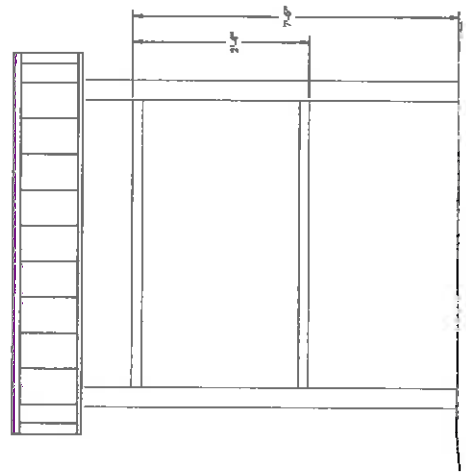
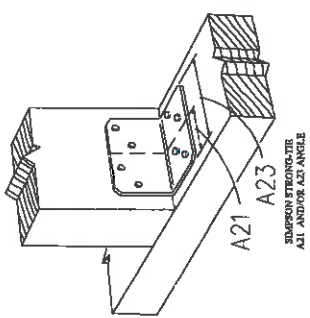
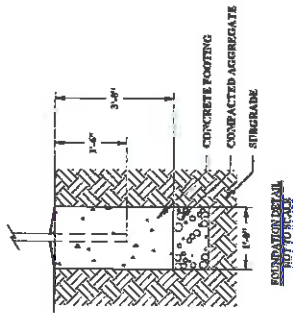
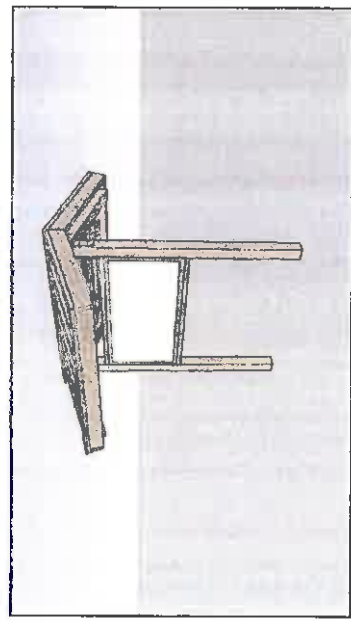

SCALE: AS SHOWN DATE: _____ DRAWN BY: _____ CHECKED BY: _____ DATE: _____ PROJECT NO.: _____ SHEET NO.: 15	THRASHER 300 APPALACHIAN BLVD., SUITE 200 HARRISBURG, PA 17110 PHONE: 717.634.1234 FAX: 717.634.1235 WWW.THRASHER.COM	WEST VIRGINIA DIVISION OF NATURAL RESOURCES ELK RIVER BOATING ACCESS SITES 800 CHIMNEY DETAILS	PROJECT NO.: _____ CONTRACT NO.: _____ SCALE: 1"=10'-0"
--	---	--	---

LABEL	QUANTITY	MANUFACTURER	CATALOG NUMBER	DESCRIPTION	LAMP	NUMBER LAMPS	FRAME	LUMENS PER LAMP	LIGHT LOSS FACTOR	WATTAGE
A	6	GREENHINE NEW ENERGY	GE-LED-NB-16-T-40V-40K-BK	16 LED TYPE II OFFICE, 700MA 4000K STREET LIGHT FIXTURE	16 4000K LED	1	GE-LED-HB-16-T2-40V-40K-BK VIT-EB	4140	1	40
B	6	GREENHINE NEW ENERGY	GE-LED-NB-16-T-40V-40K-BK	16 LED TYPE III OFFICE, 700MA 4000K STREET LIGHT FIXTURE	16 4000K LED	0	GE-LED-HB-16-T2-40V-40K-BK VIT-EB	4140	1	40
C	6	GREENHINE NEW ENERGY	GE-LED-NB-16-T-40V-40K-BK	16 LED TYPE V OFFICE, 700MA 4000K STREET LIGHT FIXTURE	16 4000K LED	0	GE-LED-HB-16-T2-40V-40K-BK VIT-EB	4140	1	40

LIGHTING FIXTURE SCHEDULE

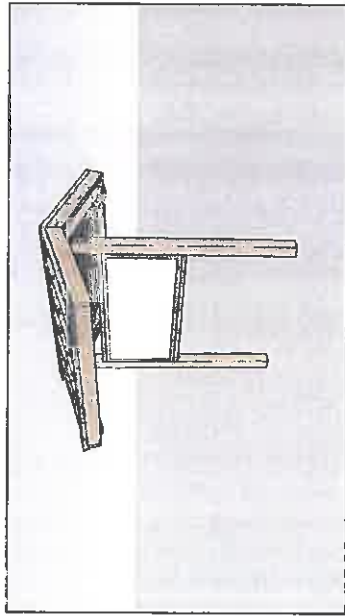

PERSPECTIVE
NOT TO SCALE

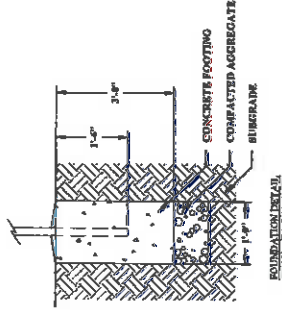

FOUNDATION DETAIL
NOT TO SCALE

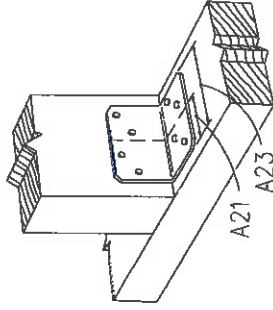

ROOF FRAMING DETAIL
NOT TO SCALE

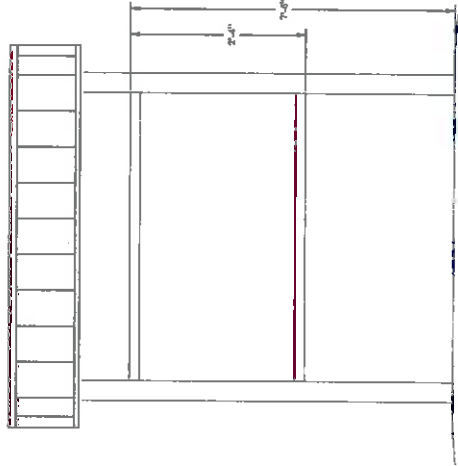

SIDE ELEVATION
NOT TO SCALE

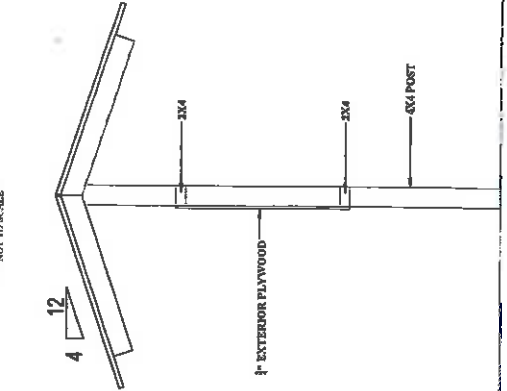

END ELEVATION
NOT TO SCALE

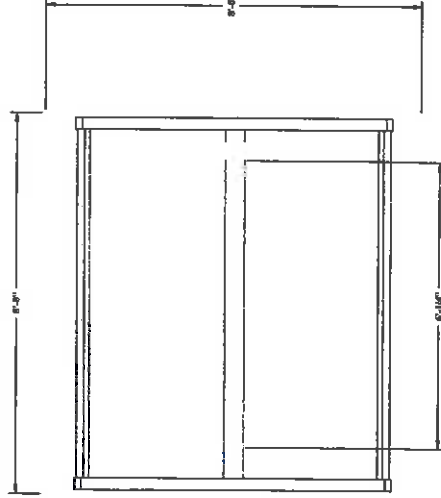

ROOF FRAMING PLAN
NOT TO SCALE

WAYFINDING KIOSK

SCALE: AS SHOWN	DATE: 11/15/2017
DRAWN BY: J. B. BROWN	CHECKED BY: J. B. BROWN
DESIGNED BY: J. B. BROWN	PROJECT NO: 17-01-030-3317
DATE PLOTTED: 11/15/2017 10:54:30 AM	

THRASHER
THE THRASHER GROUP, INC.
1701 LEBANON AVENUE
LEBANON, TN 37037

WEST VIRGINIA
DIVISION OF NATURAL RESOURCES
ELK RIVER BOATING ACCESS SITES
BLUE CREEK
DETAILS

SHEET NO. **16**

LABEL	QUANTITY	MANUFACTURER	CATALOG NUMBER	DESCRIPTION	LAMP	NUMBER LAMPS	FILENAME	LUMENS PER LAMP	LIGHT LOSS FACTOR	WATTAGE
A	3	GREENSHINE NEW ENERGY	GS-LED-NR-16-T5-40W-40K-3K	16 LED TYPE II OPTICS, 1600MA, 4000K STREET LIGHT FIXTURE	16 4000K LED	1	GS-LED-NR-16-T5-40W-40K-V111R	4140	1	40
B	0	GREENSHINE NEW ENERGY	GS-LED-NR-16-T5-40W-40K-3K	16 LED TYPE III OPTICS, 1600MA, 4000K STREET LIGHT FIXTURE	16 4000K LED	0	GS-LED-NR-16-T5-40W-40K-V112R	4140	1	40
C	0	GREENSHINE NEW ENERGY	GS-LED-NR-16-T5-40W-40K-3K	16 LED TYPE IV OPTICS, 1600MA, 4000K STREET LIGHT FIXTURE	16 4000K LED	0	GS-LED-NR-16-T5-40W-40K-V113R	4140	1	40

LIGHTING FIXTURE SCHEDULE

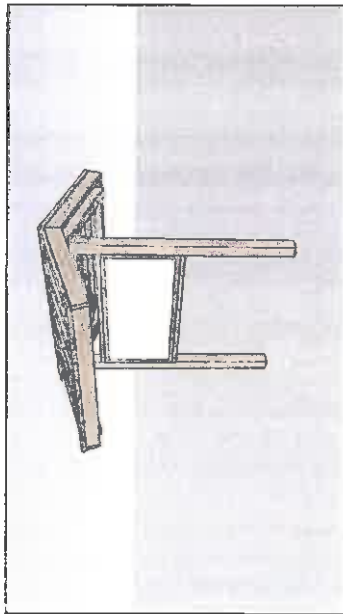

PERSPECTIVE
NOT TO SCALE

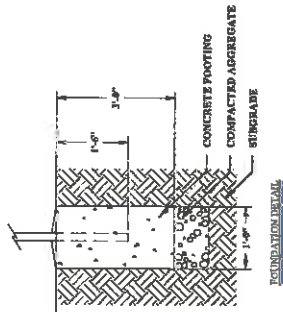

EMBEDMENT DETAIL
NOT TO SCALE

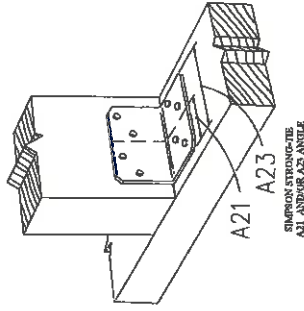

SUPPORT STRUCTURE
A21 AND A23 ANGLE
ELEVATION DETAIL
NOT TO SCALE

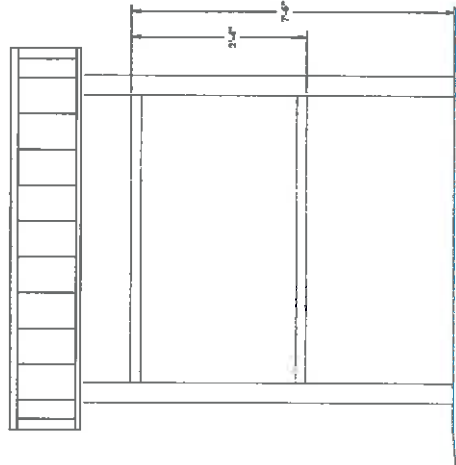

SIDE ELEVATION
NOT TO SCALE

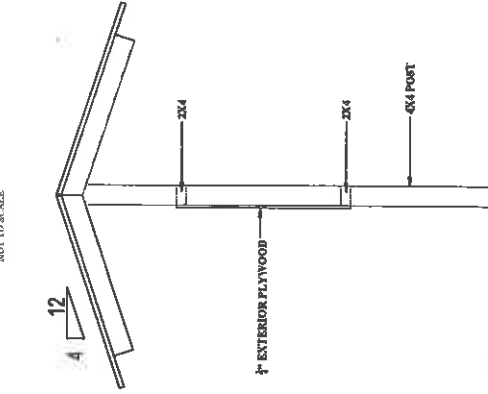

END ELEVATION
NOT TO SCALE

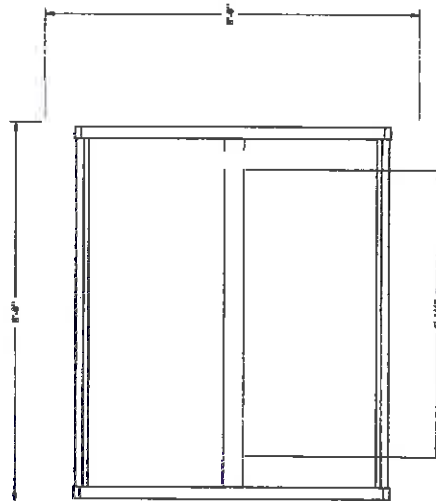

6'-4" x 6'-4"
ROOF FRAMING PLAN
NOT TO SCALE

WAYFINDING KIOSK
NOT TO SCALE

THE INFORMATION CONTAINED HEREIN IS THE PROPERTY OF THRASHER GROUP, INC. AND IS NOT TO BE REPRODUCED OR TRANSMITTED IN ANY FORM OR BY ANY MEANS, ELECTRONIC OR MECHANICAL, INCLUDING PHOTOCOPYING, RECORDING, OR BY ANY INFORMATION STORAGE AND RETRIEVAL SYSTEM, WITHOUT PRIOR WRITTEN PERMISSION FROM THRASHER GROUP, INC.

NO.	REV.	DATE	DESCRIPTION
1	01/20/20	01/20/20	ISSUE FOR PERMIT

SCALE: AS SHOWN	DATE: 01/20/20
DRAWN BY: JLD	CHECKED BY: JLD
PROJECT: WEST VIRGINIA DIVISION OF NATURAL RESOURCES	PROJECT NO.: 1-01-030-331B
300 HOSPITAL BL., CHARLESTON, WV 25301	PROJECT NO.: 1-01-030-331B

THRASHER
GROUP, INC.
300 HOSPITAL BL., CHARLESTON, WV 25301
TEL: 304.725.1100
WWW.THRASHERGROUP.COM

PHASE NO.	CONTRACT NO.

WEST VIRGINIA
DIVISION OF NATURAL RESOURCES
ELK RIVER BOATING ACCESS SITES
CLENDENIN NORTH
DETAILS

SHEET NO.
10

LABEL	QUANTITY	MANUFACTURER	CATALOG NUMBER	DESCRIPTION	LAMP	NUMBER LAMPS	WIRE GAUGE	LUMENS PER LAMP	LIGHT LOSS FACTOR	WATTAGE
A	2	GREENSHINE NEW ENERGY	GR-LED-NR-16-TL-40W-4000K-BK	16 LED TYPE III OFFICE, 700MA 4000K STREET LIGHT FIXTURE	16 4000K LED	1	14-2	4140	1	40
B	0	GREENSHINE NEW ENERGY	GR-LED-NR-16-TL-40W-4000K-BK	16 LED TYPE III OFFICE, 700MA 4000K STREET LIGHT FIXTURE	16 4000K LED	0	14-2	4140	1	40
C	0	GREENSHINE NEW ENERGY	GR-LED-NR-16-TL-40W-4000K-BK	16 LED TYPE III OFFICE, 700MA 4000K STREET LIGHT FIXTURE	16 4000K LED	0	14-2	4140	1	40

LIGHTING FIXTURE SCHEDULE

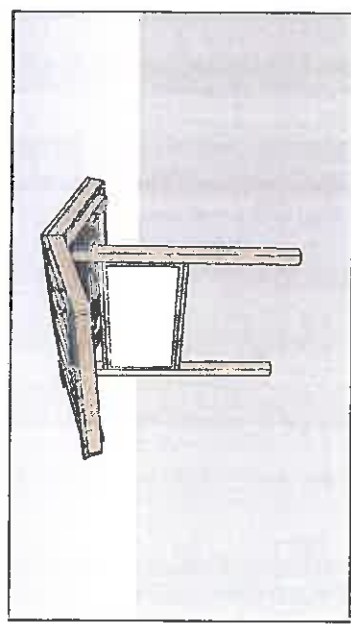

PERSPECTIVE
NOT TO SCALE

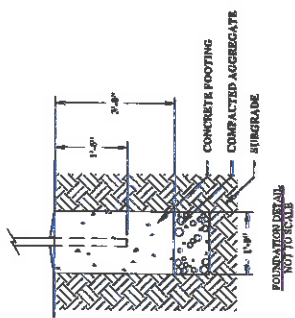

FOUNDATION DETAIL
NOT TO SCALE

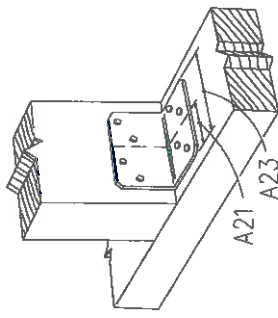

EASTING DETAIL
NOT TO SCALE

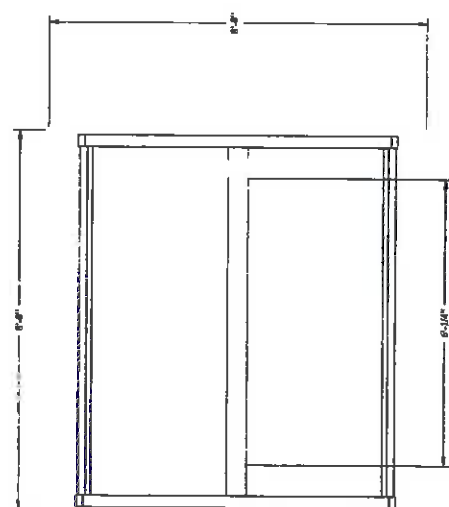

ROOF FRAMING PLAN
NOT TO SCALE

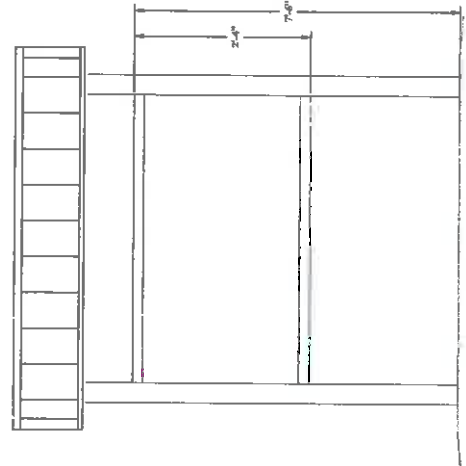

SIDE ELEVATION
NOT TO SCALE

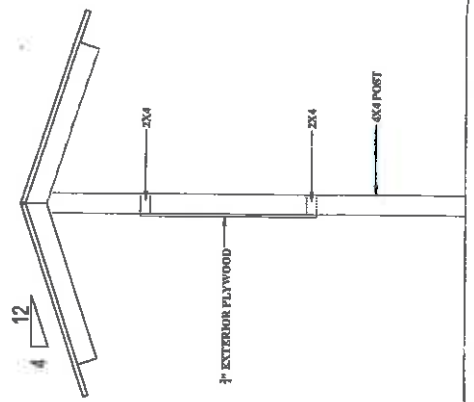

END ELEVATION
NOT TO SCALE

WAYFINDING KIOSK
NOT TO SCALE

THE INFORMATION CONTAINED HEREIN IS THE SOLE PROPERTY OF THRASHER AND SHALL NOT BE REPRODUCED OR TRANSMITTED IN ANY FORM OR BY ANY MEANS, ELECTRONIC OR MECHANICAL, INCLUDING PHOTOCOPYING, RECORDING, OR BY ANY INFORMATION STORAGE AND RETRIEVAL SYSTEM, WITHOUT THE WRITTEN PERMISSION OF THRASHER.

NO.	REV.	DATE	DESCRIPTION

SCALE: AS SHOWN
DATE: 08/14/2019
DRAWN BY: J. BERRY
CHECKED BY: J. BERRY
PROJECT NO.: 19-01-030-3321

THRASHER
THE THRASHER GROUP, INC.
200 HARRISON AVENUE, SUITE 100
PORTLAND, OREGON 97208

WEST VIRGINIA
DIVISION OF NATURAL RESOURCES
ELK RIVER BOATING ACCESS SITES
COONSWAMP PARK
DETAILS

PROJECT NO.: 19-01-030-3321
SHEET NO.: 10

LABEL	QUANTITY	MANUFACTURER	CATALOG NUMBER	DESCRIPTION	LAMP	NUMBER LAMPS	FOOTCANDLES	SLIMLINE PER LAMP	LIGHT LOSS FACTOR	WATTAGE
A	6	GREENSHINE NEW ENERGY	GS-LED-NB-16-T3-40W-4000K-BK	T3 LED TYPE III OPTICS, 7000MA 4000K STREET LIGHT FIXTURE	16-0000K LED	1	4140	4140	1	40
B	0	GREENSHINE NEW ENERGY	GS-LED-NB-16-T3-40W-4000K-BK	T3 LED TYPE III OPTICS, 7000MA 4000K STREET LIGHT FIXTURE	16-0000K LED	0	4140	4140	1	40
C	0	GREENSHINE NEW ENERGY	GS-LED-NB-16-T5-40W-4000K-BK	T5 LED TYPE V OPTICS, 7000MA 4000K STREET LIGHT FIXTURE	16-0000K LED	0	4196	4196	1	40

LIGHTING FIXTURE SCHEDULE

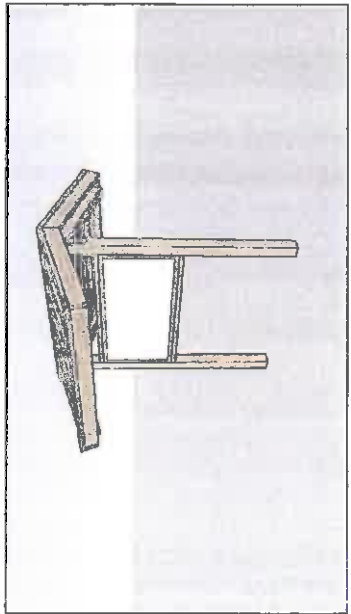

PERSPECTIVE
NOT TO SCALE

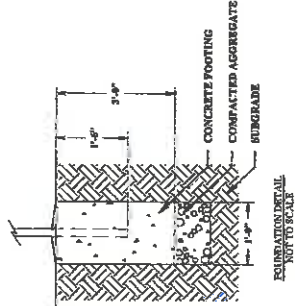

FOUNDATION DETAIL
NOT TO SCALE

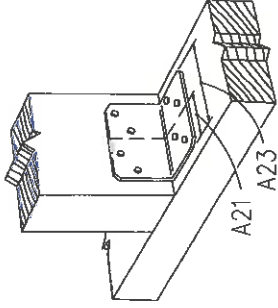

FASTENING DETAIL
NOT TO SCALE

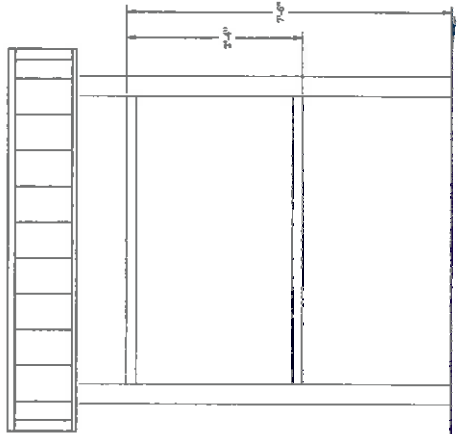

SIDE ELEVATION
NOT TO SCALE

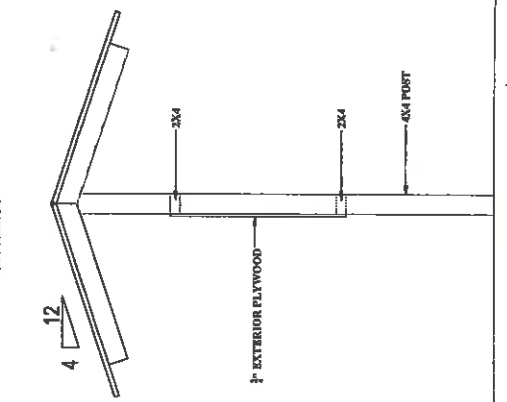

END ELEVATION
NOT TO SCALE

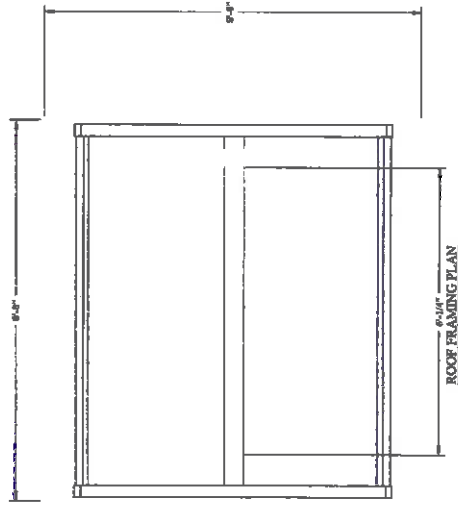

ROOF FRAMING PLAN
NOT TO SCALE

WAYFINDING KIOSK
NOT TO SCALE

<p>DATE: 08/20/2018 TIME: 10:00 AM PROJECT: WEST VIRGINIA DIVISION OF NATURAL RESOURCES ELK RIVER BOATING ACCESS SITES DRAWING: WAYFINDING KIOSK SHEET NO: 13</p>	<p>PROJECT NO: 1-01-050-3323</p>
<p>WEST VIRGINIA DIVISION OF NATURAL RESOURCES ELK RIVER BOATING ACCESS SITES CLEMENS SOUTH DETAILS</p>	
<p>THRASHER 300 ARCADE STREET, SUITE 200 CHARLOTTE, NC 28202 PHONE: 704.375.8200 FAX: 704.375.8201 WWW.THRASHER.COM</p>	
<p>NO. 1</p>	<p>DATE</p>

THE INFORMATION CONTAINED HEREIN IS THE SOLE PROPERTY OF THE DESIGNER. NO PART OF THIS DOCUMENT SHALL BE REPRODUCED OR TRANSMITTED IN ANY FORM OR BY ANY MEANS, ELECTRONIC OR MECHANICAL, INCLUDING PHOTOCOPYING, RECORDING, OR BY ANY INFORMATION STORAGE AND RETRIEVAL SYSTEM, WITHOUT THE WRITTEN PERMISSION OF THE DESIGNER.

ADDENDUM ACKNOWLEDGEMENT FORM
SOLICITATION NO.: _____

Instructions: Please acknowledge receipt of all addenda issued with this solicitation by completing this addendum acknowledgment form. Check the box next to each addendum received and sign below. Failure to acknowledge addenda may result in bid disqualification.

Acknowledgment: I hereby acknowledge receipt of the following addenda and have made the necessary revisions to my proposal, plans and/or specification, etc.

Addendum Numbers Received:

(Check the box next to each addendum received)

- | | |
|---|--|
| <input type="checkbox"/> Addendum No. 1 | <input type="checkbox"/> Addendum No. 6 |
| <input type="checkbox"/> Addendum No. 2 | <input type="checkbox"/> Addendum No. 7 |
| <input type="checkbox"/> Addendum No. 3 | <input type="checkbox"/> Addendum No. 8 |
| <input type="checkbox"/> Addendum No. 4 | <input type="checkbox"/> Addendum No. 9 |
| <input type="checkbox"/> Addendum No. 5 | <input type="checkbox"/> Addendum No. 10 |

I understand that failure to confirm the receipt of addenda may be cause for rejection of this bid. I further understand that any verbal representation made or assumed to be made during any oral discussion held between Vendor's representatives and any state personnel is not binding. Only the information issued in writing and added to the specifications by an official addendum is binding.

Company

Authorized Signature

Date

NOTE: This addendum acknowledgement should be submitted with the bid to expedite document processing.
 Revised 6/8/2012